

COMMERCIAL NETWORK

USA and Canada
BENTLEY EASYPower
www.easypower.com

Switzerland
PSI NEPLAN
www.neplan.ch

Colombia and Chile
GERS
www.gers.com.co

Australia
IENGINEERING
www.ieng.tech

UK and Ireland
GREY MATTERS
www.greymattersglobal.com

Serbia and Balkans region
ENERA
enera-doo@enera-cmc.com

France
SIMGRID
www.sim-grid.com

Brazil
ENGEPOWER
www.engepower.com

Central America and Caribbean
CORGI
www.corgia.com

Africa
DEHN AFRICA
www.dehn-africa.com

Thailand
CB SOFT+
www.cbsoftplus.com

Turkiye
EMEK
www.electricalsystemexperts.com



SINT Srl

ENGINEERING CONSULTING AND SOFTWARE

XGSLab™

SCIENCE FOR ENGINEERING

THE STATE OF THE ART OF THE
ELECTROMAGNETIC SIMULATION FOR
POWER SYSTEMS, GROUNDING,
INTERFERENCE AND LIGHTNING

GENERAL BROCHURE

[October 2025]

Visit www.xgslab.com to learn more

XGSLab strengths:

- ❖ **SCIENTIFIC:** based on electromagnetic fields theory and in particular in Maxwell Equations and Sommerfeld Integrals
- ❖ **EASY:** a program with an intuitive interface. Very easy even for beginners. Expert users in competitive tools can use XGS right away
- ❖ **WORLDWIDE:** it takes into account International (IEC), USA (IEEE) and European (EN) standards
- ❖ **VALIDATED:** accuracy validated since 1990 by comparison with analytical cases, published researches, field measures and similar programs
- ❖ **COMPLETE:** a complete virtual laboratory for the electromagnetic simulation of Power Systems, Grounding, Interference and Lightning
- ❖ **ADVANCED:** based on full-wave PEEC model and suitable for general applications, in a wide frequency range, with arbitrary conductors arrangement and many soil models including multilayer and multizone. Available in the frequency and time domain
- ❖ **POWERFUL:** a powerful code that uses parallel computing, advanced math libraries and OpenGL vector graphics
- ❖ **OPEN:** frequency dependent self and mutual impedances can be exported to EMTP® or ATP® for dynamic behavior studies. Layout data can be imported / exported from / to AutoCAD®. Numerical output can be read by MATLAB®, EXCEL®, and GOOGLE EARTH®



XGSLab Software
Best Seller in Europe
Well Established in the Whole World



SINT Srl

ENGINEERING CONSULTING AND SOFTWARE



ELECTROMAGNETIC SIMULATION FOR POWER SYSTEMS, GROUNDING, INTERFERENCE AND LIGHTNING

Are you looking for the most advanced and accurate electromagnetic simulation software for power systems, grounding, interference, and lightning analysis? Look no further than XGSLab. Our software, powered by state-of-the-art algorithms, provides engineers and researchers with the tools they need to design and analyze electromagnetic fields with precision and efficiency. Our user-friendly interface makes it easy to simulate and analyze a wide range of applications, including power systems, grounding, interference and lightning analysis. Optimize your electromagnetic design process and get the results you need with XGSLab, the industry leader in electromagnetic simulation software.

XGSLab stands for eXtended Grounding Software Laboratory.

XGSLab (or shortly XGS) has been chosen by many Universities, Utilities and top Electrical Engineering firms in the whole World.

XGS includes the modules:

- GSA (Grounding System Analysis)
- GSA_FD (Grounding System Analysis in the Frequency Domain)
- XGSA_FD (System Analysis in the Frequency Domain)
- XGSA_TD (System Analysis in the Time Domain)
- NETS (Network Solver)
- SHIELD (Lightning Shielding)
- SHIELD_A (Lightning Shielding Advanced)

The modules GSA, GSA_FD, XGSA_FD and XGSA_TD are based on the electromagnetic field theory and include the following auxiliary tools:

- SRA (Soil Resistivity Analysis)
- SSA (Soil Seasonal Analysis)
- FFA (Fast Fourier Analysis direct / inverse) (for XGSA_TD only)

The application field of modules GSA_FD, XGSA_FD and XGSA_TD is wide because they are based on the PEEC (Partial Element Equivalent Circuit) method, a numerical method for general applications powerful and flexible, a scientific method but perfectly suitable for engineering purposes. This method allows the analysis of complex scenarios including external parameters such as voltage or current generators and impedances. The implemented PEEC method solves the Maxwell equations in full wave conditions taking into account the Green functions for propagation, the Sommerfeld integrals for the earth reaction, the Jefimenko equations for electric and magnetic fields and moving from the frequency to the time domain by means the Fast Fourier Transforms.

These modules can import data from "dxf or dwg" files, and also export data and results in "dxf or dwg" files with a full interactivity with CAD tools.

In the future it will be possible to import from other popular CAD or BIM formats, for increasingly complete interactivity with other software.

Moreover, results can be also exported as "kml or kmz" files and then displayed in Google Earth®.

The module NETS is based on the PCM (Phase Components Method) and graphs theory and integrates specific routines for the calculation of the parameters of lines, cables and transformers.

The modules SHIELD and SHIELD_A are based on a full 3D geometrical and graphical model and consider the most diffused methods used for the lightning shielding design (Rolling Sphere and Eriksson Methods).

The available calculation options depend on module and license profile. For details on XGS profiles it is advisable to refer to the document "PRICE LIST".

All modules are integrated in an "all in one" package and provide professional numerical and graphical output useful to investigate any electromagnetic greatness.

All algorithms implemented in XGS are highly efficient in terms of computation speed and have been validated and tested by hundreds of Customers in the world.

XGS is easy to use by engineers who need not to be necessarily experts in the specific field, and moreover accurate, stable and fast.

Everything possible has been done to enhance user friendliness and increase productivity to this powerful tool.

The XGS modules can be grouped according to specific applications as in the following.

MODULES FOR POWER SYSTEM ANALYSIS

XGS includes the following module specifically developed for power system analysis:

- NETS: this module can be used for analysis of multi-conductor and multi-phase full meshed networks also in cases of multiple connection to earth (when the sequence components method cannot be applied) and is commonly used for the evaluation of current distribution in fault and steady state conditions in cables and power lines, including the evaluation of current along screens, armors and overhead earth wires

MODULES FOR GROUNDING AND EARTHING SYSTEM ANALYSIS

XGS includes the following modules specifically developed for grounding and earthing system analysis:

- GSA: this module can be used for analysis of underground systems at low frequency and is commonly used for small and medium size plants like substations or tower footing
- GSA_FD: this module can be used for advanced analysis of underground systems in the frequency domain from DC to about 100 MHz and is commonly used for medium and large systems size like substations, photovoltaic plants or wind plants, for cathodic protection and anode bed analysis or for calculations at high frequency
- NETS: this module can be used for the evaluation of fault current distribution and is commonly used for the split factor calculation in general conditions

MODULES FOR ELECTROMAGNETIC INTERFERENCE AND FIELDS ANALYSIS

XGS includes the following modules specifically developed for electromagnetic and fields analysis:

- GSA_FD: this module can be used for advanced electromagnetic interference analysis of underground systems in the frequency domain from DC to about 100 MHz and is commonly used for the evaluation of interference between power cables and pipelines
- XGSA_FD: this module can be used for advanced electromagnetic interference and fields analysis of aboveground and underground systems in the frequency domain from DC to about 100 MHz and is commonly used for the evaluation of interference between power lines or cables and pipelines or telecommunication systems. This module can also calculate the electromagnetic force on conductors
- XGSA_TD: this module can be used for advanced electromagnetic interference and fields analysis of aboveground and underground systems in the time domain taking into account transients with maximum bandwidth up to about 100 MHz and is commonly used for the evaluation of interference in transient conditions. This module can also calculate the electromagnetic force on conductors
- NETS: this module can be used for electromagnetic interference analysis of aboveground and underground systems at power frequency, and is commonly used for the evaluation of interference between power lines or cables or railways and pipelines

MODULES FOR LIGHTNING SYSTEM ANALYSIS

XGS includes the following modules specifically developed for lightning system analysis:



- XGSA_TD: this module can be used for advanced electromagnetic interference and fields analysis of aboveground and underground systems in the time domain taking into account transients with maximum bandwidth up to about 100 MHz and is commonly used for the evaluation of lightning or transient effects. This module can also calculate the electromagnetic force on conductors
- SHIELD: this module can be used for the lightning shielding design using the Rolling Sphere or Eriksson methods and can be used for the evaluation of the protection against direct lightning strokes of structures of any height or up to 60 m height in case of relevant protrusions. This module has been developed for lightning engineers, and can be used for all types of buildings, substations or industrial plants
- SHIELD_A: this module can be used for the advanced lightning shielding design using the Rolling Sphere method and can be used for the evaluation of the protection against direct lightning strokes of special structures of any height and shape. This module has been developed mainly for lightning specialists, and in particular for structures very tall and with relevant protrusions, like for instance wind towers

Modules GSA, GSA_FD, XGSA_FD and XGSA_TD include the tools SRA (Soil Resistivity Analysis) and SSA (Soil Seasonal Analysis) for the multilayer soil modelling starting from soil resistivity measurements, soil parameters and local climatic conditions.

Module XGSA_TD includes the tool FFA for direct and inverse Fast Fourier Transforms in order to move from the frequency to time domain and vice versa.



GROUNDING SYSTEM ANALYSIS

GSA is a widely utilized and recognized module for grounding and earthing grid calculations and design at low frequency including soil resistivity analysis.

GSA takes into account International (IEC/TS 60479-1:2018), European (EN 50522:2022) and American (IEEE Std 80-2013) Standards.

XGS is then also according to widespread national standards or code of practice like for instance Indian (IS 3043:2018) Standards.

GSA is based on a PEEC static numerical model and to the equipotential condition of the electrodes and can analyse the low frequency performance of grounding systems composed by many distinct electrodes of any shape but with a limited size into a uniform or multilayer soil model.



GROUNDING SYSTEM ANALYSIS in the FREQUENCY DOMAIN

GSA_FD is a module for grounding and earthing grid calculation and design in the frequency domain, including soil resistivity analysis and represents the state of the art of advanced grounding software.

GSA_FD is based on a PEEC full wave numerical model and can be applied in general conditions with systems composed by many distinct electrodes of any shape, size and kind of conductor (solid, hollow or stranded and coated or bare) into a uniform, multilayer or multizone soil model in a large frequency range from DC to about 100 MHz. GSA_FD can also consider single core and multicores screened conductors. It is moreover important to consider that GSA_FD is able to take into account the frequency dependence of soil parameters according to many models and in particular in the model with a general consensus indicates in the CIGRE TB 781 2019.

GSA_FD allows the analysis also of large electrodes whose size is greater than the wavelength of the electromagnetic field as better specified in the following. GSA_FD then overcomes all limits related to the equipotential condition of the electrodes on which GSA is based. With the equipotential condition hypothesis, the maximum touch voltage is widely underestimated and this may result in grounding system oversizing with additional cost sink even 50%.

The implemented model considers both self and mutual impedances. Experience shows that often, mutual impedances cannot be neglected not even at power frequency. A few competitors take into account self impedance and a very few competitors consider the mutual impedance effects and this can lead to significant errors in calculations. Neglecting self impedance effects is often unacceptable, but neglecting mutual impedances can lead to errors over the 20% in calculations also at power frequency. It is important to consider that calculation accuracy often means saving money and indeed, so GSA_FD can allow a significant cost saving in grounding system construction and materials.

GSA_FD can also calculate magnetic fields due to grounding systems or cable, and electromagnetic interference (induced current and potential due to resistive, capacitive and inductive coupling) between grounding systems or cable and pipeline or buried electrodes in general.

In DC conditions, GSA_FD is a good tool for cathodic protection and anode bed analysis with impressed current systems.



SYSTEM ANALYSIS in the FREQUENCY DOMAIN

XGSA_FD is a module for analysis of aboveground and underground systems in the frequency domain.

XGSA_FD extends the GSA_FD application field to the aboveground systems.

Also XGSA_FD is based on a PEEC full wave numerical model and can be applied in general conditions with same conductors and in the same frequency range of GSA_FD.

Using screened conductors XGSA_FD can simulate gas insulated systems like GIS and GIL.

XGSA_FD can also manage catenary conductors and bundle conductors too and can take into account sources where potential or leakage current and longitudinal current are forced and independent by other conditions. For these reasons XGSA_FD is probably one of the most powerful and multipurpose tools on the market for these kind of calculations.

In addition to GSA_FD, XGSA_FD can calculate electromagnetic fields and interference between aboveground and underground systems (for instance between overhead or underground power lines and installation as pipelines, railways or communications lines).

Moreover XGSA_FD can calculate the electromagnetic force (Lorentz force) on conductors.

Finally, XGSA_FD can consider Surge Protective Devices.

XGSA_FD integrates also some powerful tools for the evaluation of the corona effects (power losses and radiofrequency interference) and the evaluation of the electromagnetic force effects on busbars and supports.



SYSTEM ANALYSIS in the TIME DOMAIN

XGSA_TD is a module for analysis of aboveground and underground systems in the time domain.

XGSA_TD is a powerful module which extends the XGSA_FD application field to the time domain.

In this regard, XGSA_TD uses the so called "frequency domain approach". This approach is rigorous and allows considering the frequency dependence of soil parameters.

As known, a transient can be considered as the superposition of many single frequency waveform calculated with the forward Fast Fourier Transforms (FFT).

Using the frequency domain PEEC model implemented in XGSA_FD it is then possible calculate a response for each of these single frequency waveform.

The resulting time domain response can be obtained by applying the inverse Fast Fourier Transform to all these responses calculated in the frequency domain.

The calculation sequence implemented in XGSA_TD is also called FFT – PEEC – IFFT.

XGSA_TD has been tested for the simulation of transients with a maximum frequency spectrum up to 100 MHz and then can be used for switching transients, lightning and also in fault transients in GIS.

XGSA_TD can consider transients with known equations like Double Exponential, Pulse or Heidler (transients used in EMC studies).

XGSA_TD can also consider transients with arbitrary equations or recorded and then known as a discrete number of samples (transients used in lightning and HV studies).

Moreover XGSA_TD can calculate the electromagnetic force (Lorentz force) on conductors.



SINT Srl

ENGINEERING CONSULTING AND SOFTWARE

XGSA_TD includes an option to export frequency dependent self and mutual impedances to EMTP® or ATP® in order to simulate with a rigorous model the dynamic behaviour of large grounding systems during electromagnetic transients.



NETWORK SOLVER

NETS is a very flexible tool able to solve full meshed multi-conductor and multi-phase networks taking into account all the neutral conductors paths as well as the earth path.

NETS is based on the phase components method (and then on Kirchhoff laws) and graphs theory for multi-conductor and multi-phase systems.

The phase components method is general and overcomes the limits of the classic sequence components method. The sequence component method is well established since 1918, but it can be used only with symmetrical systems or for systems quasi-symmetrical like the common transmission power lines (overhead lines and cables) or transformers. Non-symmetrical conditions could happen, for instance in case of power lines when the phase geometry is not equilateral and transposition is not used.

Moreover, the sequence component method cannot be used in case of multiple grounded systems or in case of problems that involve currents to earth.

The phase components method can be used to represent power systems as multi-conductor networks enabling the consideration of non-symmetrical systems also in presence of multiple grounding circuits.

The network components (generators, lines, single core and multicore cables, transformers, loads, switches, faults ...) are represented using multi-port cells and the connection between cells is obtained by means of multi-port buses.

NETS considers also a special hybrid cell where cables, lines and conductors (pipes, rails, counterpoises ...) can be combined in a single multi-port cell. This special cell can be useful for the evaluation of electromagnetic interferences in case of powerline or railways corridors and the calculation of current distribution in railways.

The grounding systems (substation grids, tower footings ...) can be specified in an arbitrary way.

NETS calculates lines, cables and transformers parameters starting on data usually available in commercial data sheet.

NETS includes a converter from the sequence domain to the phase domain. This tool can convert sequence impedances matrix to phase impedance matrix.

Like the other XGS modules, also NETS has been thought for a use as general as possible.

NETS can be used to solve transmission and distribution networks in steady state or fault conditions and to calculate potentials and currents or any kind of short circuit currents with or without fault impedances.

In particular, NETS can be used for the calculation of the fault current distribution in power networks and between power circuits and earth. An accurate knowledge of the fault current distribution is crucial in grounding, mitigation to reduce interference on communication circuits and pipelines, power system protections calibration and coordination, neutral grounding resistor sizing and many other applications.

NETS is also useful to calculate data input for other XGS modules (for instance the split factor and the current to earth) without unrealistic assumptions as for instance, magnitude of fault current known and unaffected by grounding impedances, impedances of overhead earth wires or tower footing resistances uniform along the line, or again, infinite length of lines ...

Moreover, NETS represents the link between XGS and the most diffused commercial software for power system analysis.



LIGHTNING SHIELDING

SHIELD is a powerful full 3D graphical application for the evaluation of the protection of structures from direct lightning strokes using the Rolling Sphere and the Eriksson methods.

SHIELD is based on a numerical model that consider vertical direct lightning strokes, and is then suitable for structures of any height or up to 60 m height in case of relevant protrusions such as balconies or viewer platforms.

SHIELD takes into account International (IEC 62305-3:2024), European (EN 62305-3:2025) and American (IEEE Std 998-2012) Standards but as known, the Rolling Sphere Method is considered by many other standards (NFPA, AS ...).

When the Rolling Sphere Method is set, SHIELD first generates a 3D surface corresponding to all possible points that can be touched by the surface of the sphere with a specific radius as it rolls over the air termination system. The air termination system can be composed of any combination of masts and wires (catenary wires included). This surface defines the protected volume.

The protected volume is then superposed to the structure to be protected. The parts of the structure to be protected that protrudes over this surface are not protected.

It is also possible to evaluate the protection with a given safety margin on the distance between protected volume surface and structures to be protected.

If the method is applied to the structure to be protected, it can identify the possible lightning strokes impact points and gives indications for the air termination positioning.

When the Eriksson Method is set, SHIELD generates the collection area of air termination system and structure to be protected.

The lightning protection system is effective when collection area of air termination system includes collection area of structure to be protected.

The User can modify the lightning protection system and generate again the protected volume or collection areas. This iterative process allows to get an effective shield.



LIGHTNING SHIELDING ADVANCED

SHIELD_A is a powerful full 3D graphical application for the evaluation of the protection of structures from direct lightning strokes using the Rolling Sphere method.

SHIELD_A is based on analytical model that consider vertical and lateral direct lightning strokes, and is then suitable for special structures of any height and shape.



SINT Srl

ENGINEERING CONSULTING AND SOFTWARE

APPLICATIONS

	GSA	GSA_FD	XGSA_FD	XGSA_TD	NETS	SHIELD	SHIELD_A
Grounding (equipotential systems)	✓	✓	✓	✓			
Grounding (general conditions)		✓	✓	✓			
Cathodic Protection Systems		✓	✓				
Magnetic Fields		✓	✓	✓			
Electric Fields			✓	✓			
Electromagnetic Forces			✓	✓			
Electromagnetic Interferences			✓	✓			
Corona Effects			✓				
Switching transients, Lightning and Fault transients in GIS				✓			
Steady State or Short Circuit Current Solver for Full Meshed Multi-conductor and Multi-phase Networks					✓		
Current Distribution and Electromagnetic Interference in Shared Corridors with Powerlines or Railways and Pipelines					✓		
Lightning Shielding with Rolling Sphere Method for structures of any height or up to 60 m height in case of relevant protrusions						✓	
Lightning Shielding with Rolling Sphere Method for special structures of any height and shape							✓
Lightning Shielding with Eriksson Method						✓	



GROUNDING SYSTEM ANALYSIS

GSA can be used for analysis of underground systems at low frequency and is commonly used for small and medium size plants like substations. GSA includes the tools SRA and SSA for soil resistivity analysis, soil seasonal analysis and multilayer soil modelling. GSA is highly appreciated for its ease of use, user interface and quality of graphic output.

GENERAL DESCRIPTION

GSA is based on a PEEC static numerical model and to the equipotential condition of the electrodes and can analyse the low frequency performance of grounding systems composed by many distinct electrodes of any shape but with a limited size into a uniform or multilayer soil model.

GSA can take input data in the form of either graphical (from "dxf or dwg" files or from the integrated CAD) or numerical and render powerful graphical facilities via it's optimised and validated computation algorithms, thus making it an indispensable tool for grounding system design and verification.

GSA includes the modules SRA to calculate multilayer soil model parameters starting from measured soil resistivity data and SSA to calculate the effects of seasonal climate change.

GSA is essentially a low frequency tool but in several practical cases (with little electrodes), it can be also useful to calculate the impulse impedance of electrodes under lightning currents with an accuracy level adequate for many engineering applications.

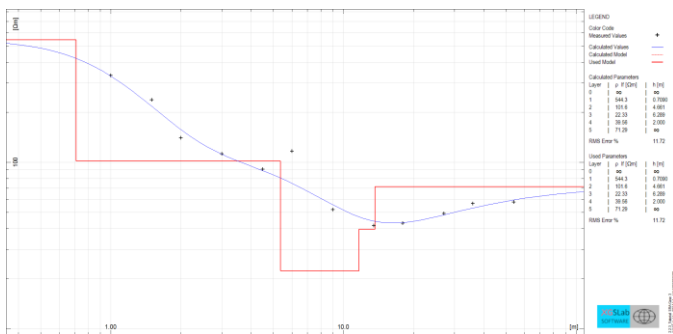

Soil resistivity measures and parameters of a five layers soil model - Log scale

INPUT DATA

- Electrical data (e.g. single phase to earth fault current, data for calculation of earthing current, reference standard, intervention time of protections, eventually additional resistance between feet and earth surface or gloves, etc.)
- Geometrical data (e.g. grounding system layout of all electrodes (up to 999), conductors cross section, coating thickness, material properties, etc.). Each electrode consists in a network of arbitrarily connected (or separated) conductors
- Physical data (e.g. soil resistivity or apparent resistivity measured values, superficial thin layer characteristics, etc.)

OUTPUT RESULTS

- Decrement factor (Df) as per IEEE standard
- Split factor (r) as per EN standard or (Sf) as per IEEE standard
- Earthing current
- Minimum cross section of grounding system conductors for thermal specification
- Uniform or multilayer soil model parameters from on site measures values of apparent resistivity with Wenner or Schlumberger methods
- Reduction factor of touch and step voltages due to a superficial thin layer (Cs) as per IEEE standard
- Maximum permissible touch and step voltages as per IEC, EN and IEEE standards taking into account the body resistance and possibly additional resistance (shoes, gloves ...). With IEC and EN standards both, prospective and permissible values of touch and step voltages are given
- Ground resistance and Ground Potential Rise values of all electrodes
- Distribution of leakage current from the electrodes with 1D, 2D and 3D graphical representation to verify the efficiency of specific grounding system parts
- Maximum electric field value close to the electrodes (useful to quickly check if the soil ionization phenomenon can occur)
- Earth potentials and prospective and effective touch and step voltages distributions on straight lines or rectangular areas or multi-areas lying on or below the soil surface by 2D and 3D coloured graphic representations, for individuation of safe and hazardous areas
- List of material used for grounding system (wires and rods)
- Orthographic projections or isometric representations of grounding system

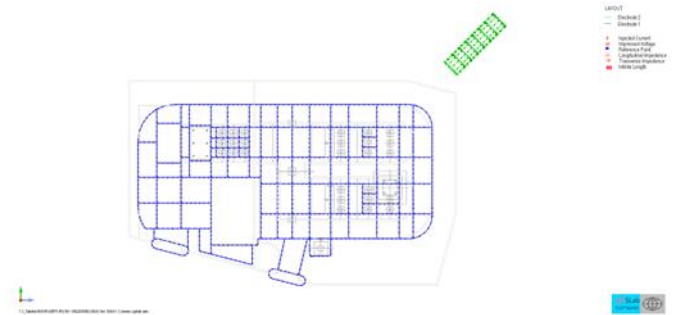

Grounding system layout - Substation

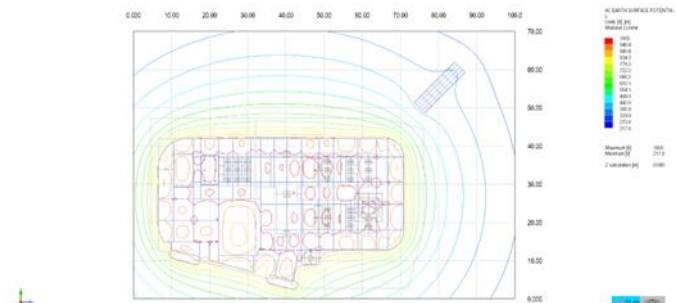

Earth surface potential - Substation - Contours option

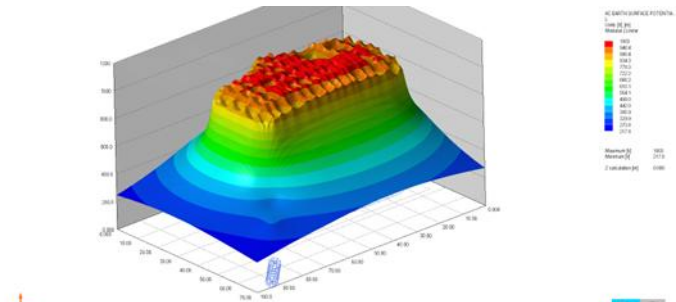

Earth surface potential - Substation - Colors option

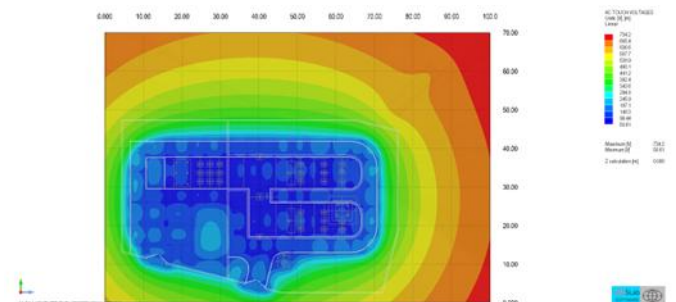

Touch voltages – Substation - Colors option



SINT Srl

ENGINEERING CONSULTING AND SOFTWARE

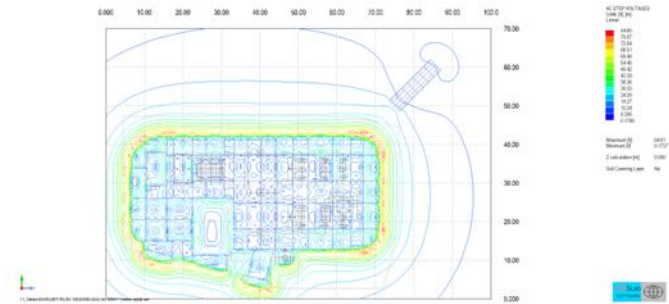

Step voltages – Substation - Contours option

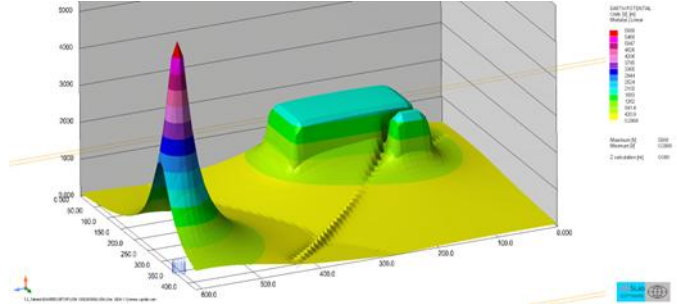

Earth surface potential - Factory – Colors option

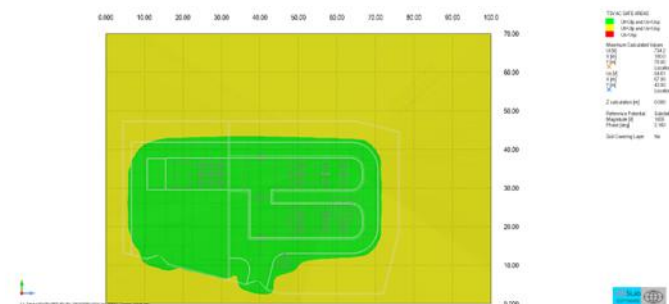

Touch and step voltages safe areas - Substation

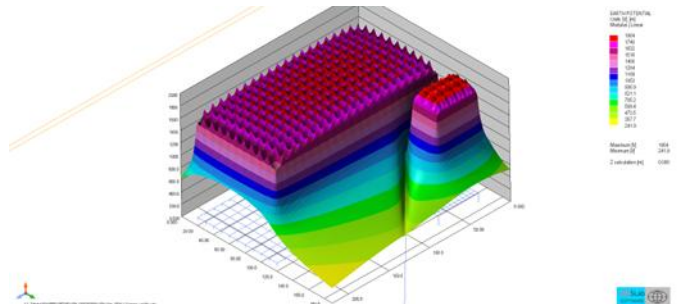

Earth surface potential - Factory – Colors option

MAIN FEATURES

- Calculation model based on PEEC method in static conditions
- Possibility to consider International (IEC/TS 60479-1:2018), European (EN 50522:2022) and American (IEEE Std 80-2013) standards
- Possibility to import grid layout from "dxf or dwg" files
- Automatic debug of data before calculation
- Analysis of grounding systems of any shape, with choice of the total number of elementary sources
- Possibility to analyse up to 999 distinct electrodes on the same calculation, including for instance return electrodes, transmission line grounding systems or floating potential underground electrodes
- Possibility to energize electrodes using both current injections or impressed potentials
- Characterization of soil with a uniform or multilayer model. Beyond this a superficial thin layer can be added
- Possibility to analyse electrodes partially insulated or encased in concrete or buried in treated soil to lower resistivity
- Libraries with typical properties of soil, soils covering, concrete and backfill materials
- Possibility to export layout data and results in "dxf or dwg" file
- Possibility to export graphic outputs to other WINDOWS® applications
- Possibility to choose the language (English, German, French, Italian, Spanish, Portuguese)

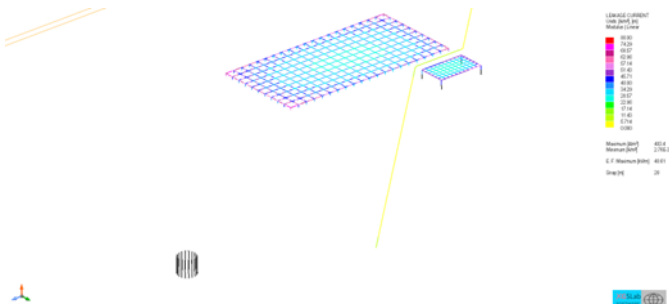

Leakage current - Factory

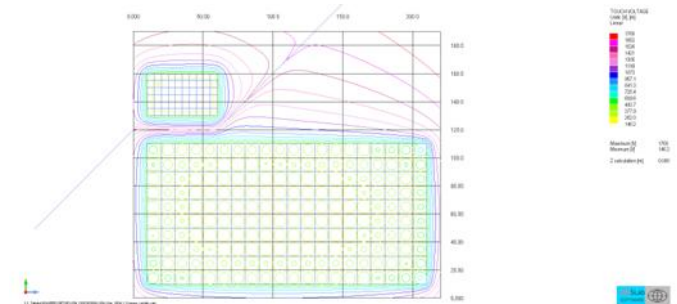

Touch voltages - Factory - Contours option

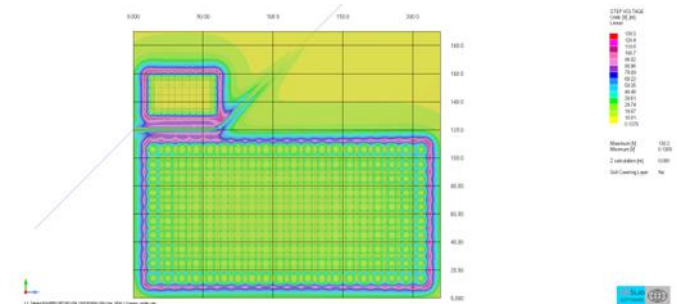

Step voltages - Factory - Colors option



Touch and step voltages safe areas - Factory



SINT Srl

ENGINEERING CONSULTING AND SOFTWARE



GROUNDING SYSTEM ANALYSIS in the FREQUENCY DOMAIN

GSA_FD can be used for advanced analysis of underground systems in the frequency domain from DC to about 100 MHz and is commonly used for medium and large systems size like substations, photovoltaic plants or wind plants, for cathodic protection and anode bed analysis or for calculations at high frequency. GSA_FD can be used also for advanced electromagnetic interference analysis of underground systems in the frequency domain from DC to about 100 MHz and is commonly used for the evaluation of interference between power cables and pipelines. GSA_FD includes the tools SRA and SSA for soil resistivity analysis, soil seasonal analysis and multilayer soil modelling. GSA_FD is highly appreciated for its power and accuracy and is irreplaceable where the hypothesis of equipotential condition of the electrode is not acceptable.

GENERAL DESCRIPTION

GSA_FD is based on a PEEC full wave numerical model and can be applied in general conditions with systems composed by many distinct electrodes of any shape, size and kind of conductor (solid, hollow or stranded and coated or bare) into a uniform, multilayer or multizone soil model in a large frequency range from DC to about 100 MHz. GSA_FD can also consider single core and multicore screened conductors. It is moreover important to consider that GSA_FD is able to take into account the frequency dependence of soil parameters according to many models including Messier, Visacro - Portela, Visacro - Alipio and the model with a general consensus indicates in the CIGRE TB 781 2019.

The graphical (from "dxf or dwg" files or from the integrated CAD) and numerical input data, the optimised and validated computation algorithms, the powerful graphical facilities render GSA_FD an indispensable tool for grounding system design and verification, when the drop voltage on conductors cannot be ignored.

GSA_FD includes the modules SRA to calculate multilayer soil model parameters starting from measured soil resistivity data and SSA to calculate the effects of seasonal climate change.

GSA_FD can also consider a multizone soil model. A multizone soil model should be used when the size of the conductors network is so large that the horizontal soil resistivity changing are more significant than vertical variations.

GSA_FD is one of the most powerful and general software on the market for grounding system analysis and can be used to solve electromagnetic compatibility or interference problems due to resistive, capacitive and inductive coupling in the earth.

GSA_FD is also useful to calculate magnetic field due to grounding systems or buried cables and can be used to investigate the effectiveness of passive loop mitigation systems.

In DC conditions, GSA_FD can be used for the cathodic protection and anode bed analysis, with impressed current systems involving extensive coated and uncoated buried structure.

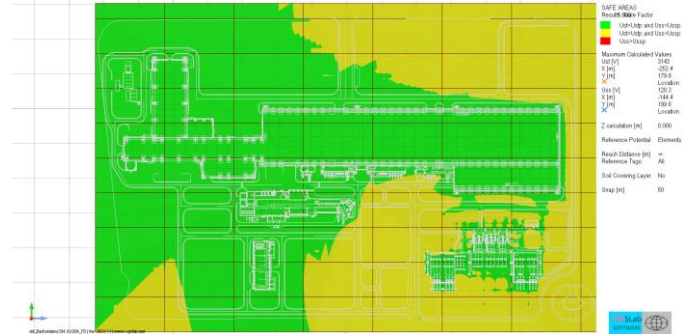

Touch and step voltages safe areas - Large factory

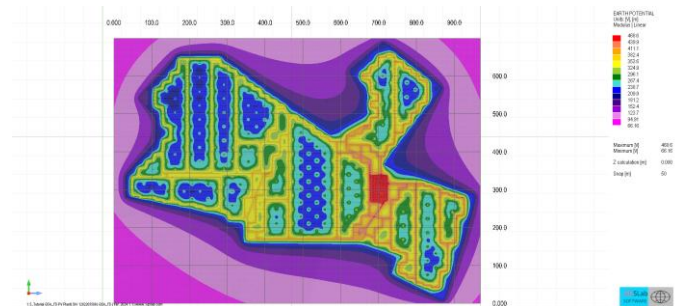

Earth surface potential - PV plant - Colors option

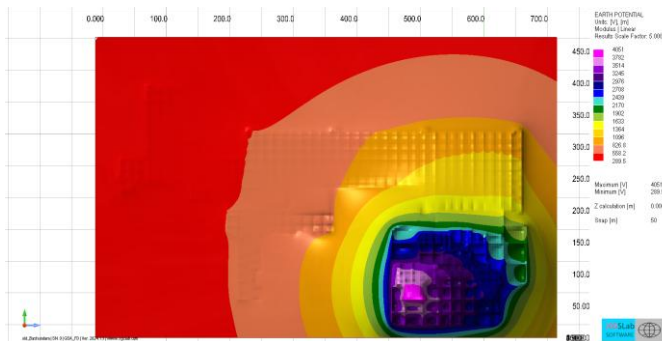

Earth surface potential - Large factory - Colors option

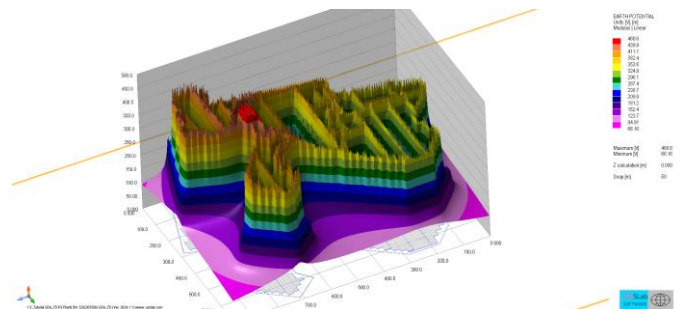

Earth surface potential - PV plant - Colors option

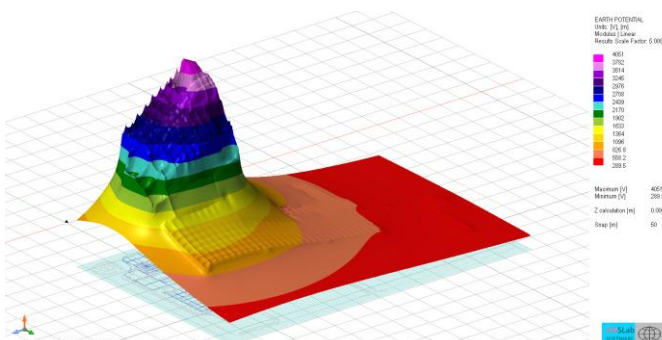

Earth surface potential - Large factory - Colors option

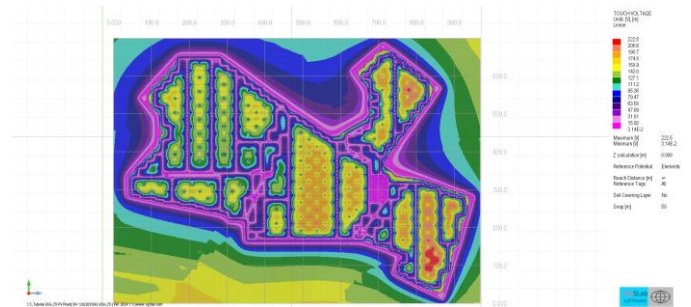

Touch voltage - PV plant - Colors option

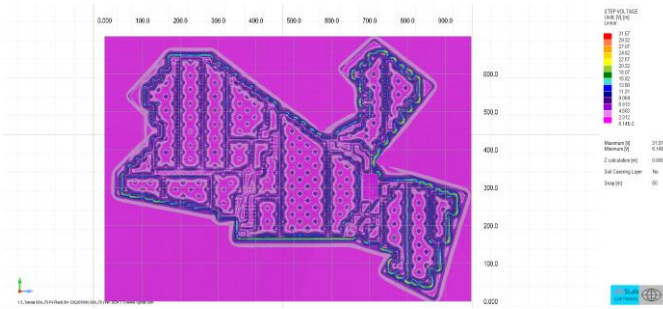

Step voltage - PV plant – Colors option

INPUT DATA (in addition to GSA)

- Additional Electrical data (e.g. injected current or specified potential in an arbitrary number of points, impressed or induced EMF, operative frequency, additional longitudinal impedances, etc.)
- Additional Geometrical data (topology of the conductors network, conductors and screened conductors cross section, coating thickness, material properties, etc.)
- Additional Physical data (e.g. soil permittivity, model for frequency dependence of soil parameters, etc.)

OUTPUT RESULTS (in addition to GSA)

- Ground impedance and Ground Potential Rise of all reference points (ground impedance is calculated as ratio between its GPR of the specific point and the total injected current in the electrodes)
- Distribution of leakage current from the electrodes with 1D (magnitude, real and imaginary), 2D and 3D graphical representation to verify the efficiency of specific grounding system parts
- Distribution of longitudinal current (transferred or induced) on the electrodes with 1D (magnitude, real and imaginary), 2D and 3D graphical representation
- Distribution of potential (transferred or induced) on the electrodes with 1D (magnitude, real and imaginary), 2D and 3D graphical representation
- Distribution of complex power on the electrodes with 1D (magnitude, real and imaginary), 2D and 3D graphical representation
- Magnetic field distributions on horizontal straight line or rectangular areas or multi-areas with 1D, 2D and 3D coloured graphic representations, for individuation of safe and hazardous areas

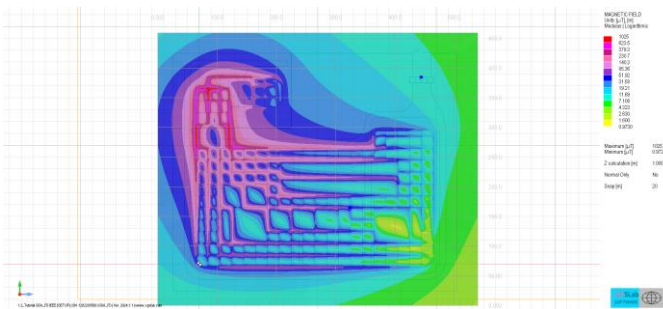

Magnetic field - Large factory

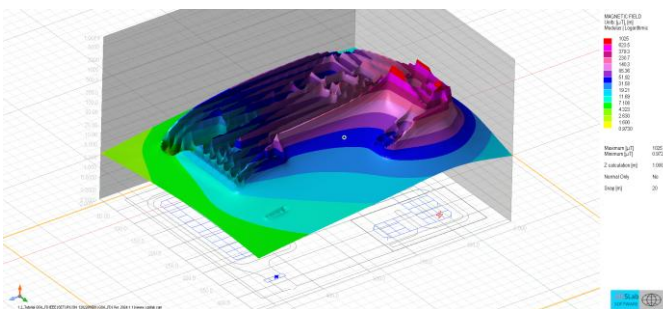

Magnetic field - Large factory



Leakage current - Large factory



Longitudinal current - Large factory



Potential - Large factory

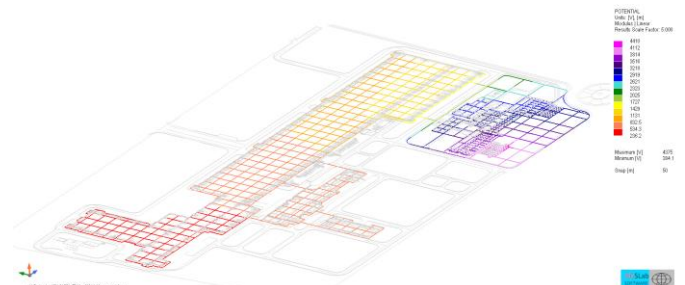

Potential - Large factory

MAIN FEATURES (in addition to GSA)

- Calculation model based on "PEEC" method in full-wave conditions
- Automatic advanced debug of data before calculation
- Automatic recognition of the connections between conductors
- Possibility to consider the soil permittivity
- Possibility to consider the frequency dependence of soil parameters and allows setting the used model choosing from the most established
- Possibility to analyse up to 999 distinct underground electrodes on the same calculation
- Possibility to consider additional longitudinal and transverse impedances
- Possibility to consider energization using both multiple current and voltage sources
- Possibility to analyse electrodes buried in a multizone soil model

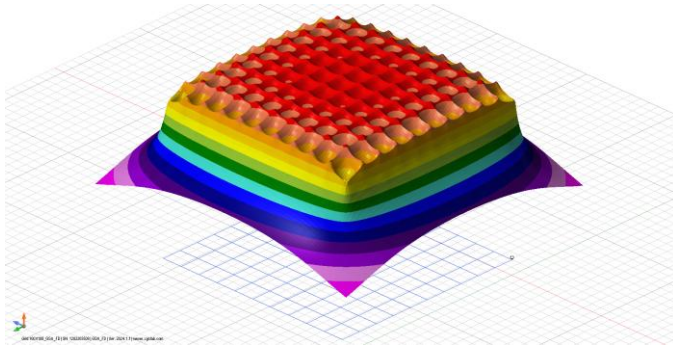

Earth surface potential - 100 Hz or less

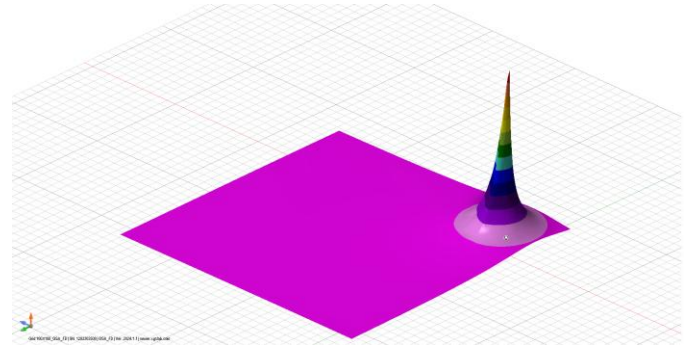

Earth surface potential - 1 MHz

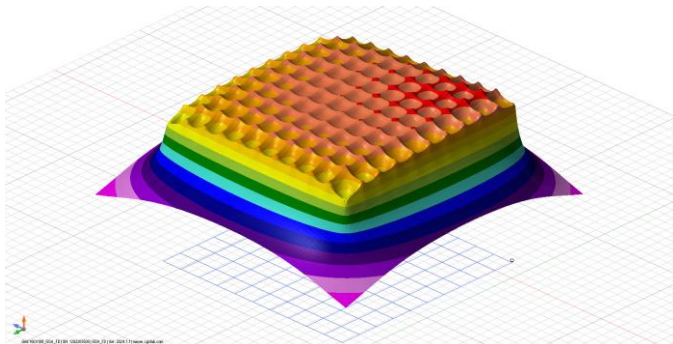

Earth surface potential - 1 kHz

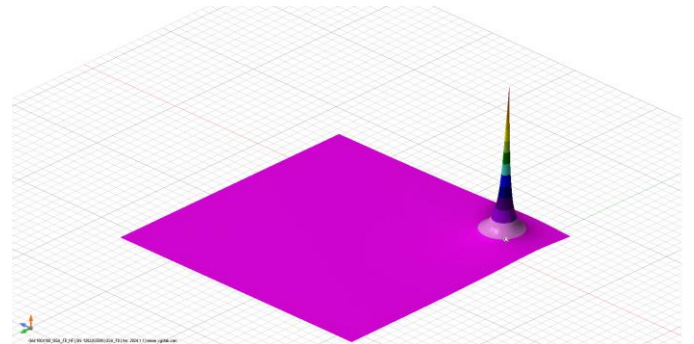

Earth surface potential - 10 MHz

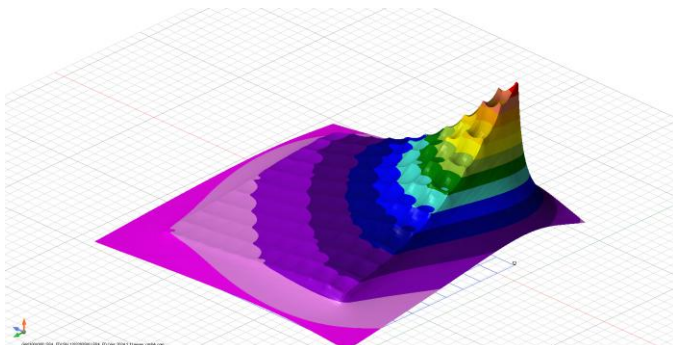

Earth surface potential - 10 kHz

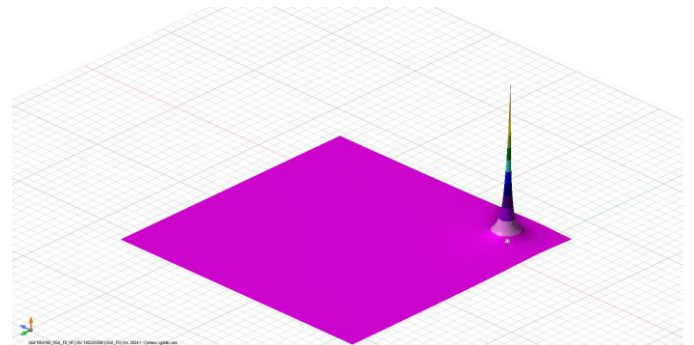

Earth surface potential - 100 MHz

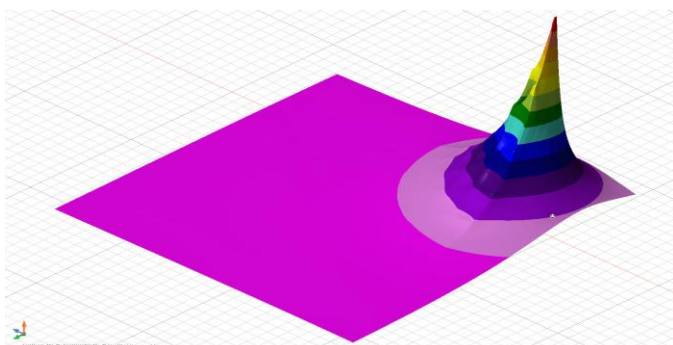

Earth surface potential - 100 kHz

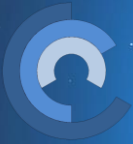

SINT Srl

ENGINEERING CONSULTING AND SOFTWARE



SYSTEM ANALYSIS in the FREQUENCY DOMAIN

XGSA_FD can be used for advanced electromagnetic interference and fields analysis of aboveground and underground systems in the frequency domain from DC to about 100 MHz and is commonly used for the evaluation of interference between power lines or cables and pipelines or telecommunication systems. This module can also calculate the electromagnetic force on conductors.

XGSA_FD contains GSA_FD and can be used also for advanced grounding systems analysis.

XGSA_FD includes the tools SRA and SSA for soil resistivity analysis, soil seasonal analysis and multilayer soil modelling.

XGSA_FD is highly appreciated for its power and accuracy and for the wide field of application.

GENERAL DESCRIPTION

XGSA_FD extends the GSA_FD application field to the overhead systems.

Also XGSA_FD is based on a PEEC full wave numerical model and can be applied in general conditions with same conductors and in the same frequency range of GSA_FD. Using screened conductors XGSA_FD can simulate gas insulated systems like GIS and GIL.

XGSA_FD can also manage catenary conductors and bundle conductors too (solid, hollow or stranded and coated or bare) and can take into account sources, that are conductors where potential or leakage current and longitudinal current are forced and independent by other conditions.

XGSA_FD is a multipurpose software and its use is not limited to specific cases. XGSA_FD application field includes grounding system analysis but is oriented in particular way to solve electromagnetic compatibility or interference problems due to resistive, capacitive and inductive coupling in air or in the earth.

For instance, XGSA_FD can evaluate electromagnetic interference between overhead or underground power lines and installation as pipelines, railways or communications lines.

XGSA_FD is also useful to calculate magnetic and electric fields due to underground or overhead electrodes (grounding systems, buried cables, overhead power lines) and can be used to investigate the effectiveness of passive loop mitigation systems.

Moreover XGSA_FD can calculate the electromagnetic force (Lorentz force) on conductors.

Finally, XGSA_FD can consider Surge Protective Devices.

XGSA_FD integrates also some powerful tools for the evaluation of the corona effects (power losses and radiofrequency interference) and the evaluation of the electromagnetic force effects on busbars and supports.

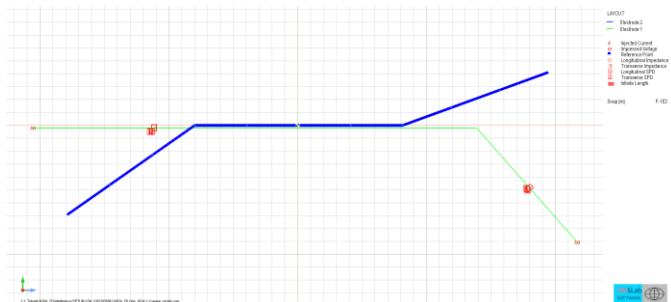

Interference layout between overhead power line (blue) and pipeline (green)

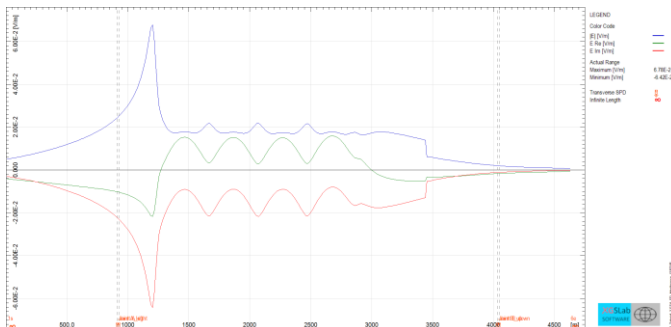

Induced EMF on the pipelines (blue magnitude, green real, red imaginary)

INPUT DATA (in addition to GSA_FD)

- Additional Electrical data (e.g. conductors with forced potentials or leakage currents or longitudinal current, additional longitudinal and transverse impedances, etc.)
- Additional Geometrical data (e.g. overhead system layout and topology of all electrodes (up to 999), catenary constant, bundle diameter, bundle conductors number, conductor conductors section, coating thickness, material properties etc.)

OUTPUT RESULTS (in addition to GSA_FD)

- Distribution of leakage current, longitudinal current, potential, electromotive force and complex power on the overhead electrodes with 1D (magnitude, real and imaginary), 2D and 3D graphical representation
- Magnetic field distributions on arbitrarily oriented straight line or horizontal or vertical rectangular areas or multi-areas with 1D, 2D and 3D coloured graphic representations, for individuation of safe and hazardous areas
- Magnetic flux across horizontal or vertical rectangular areas, for individuation of induced EMF and evaluation of separation distance
- Electric field distributions on arbitrarily oriented straight line or horizontal or vertical rectangular areas or multi-areas with 1D, 2D and 3D coloured graphic representations, for individuation of safe and hazardous areas
- Distribution of electromagnetic force on underground and overhead electrodes with 1D, 2D and 3D graphical representation

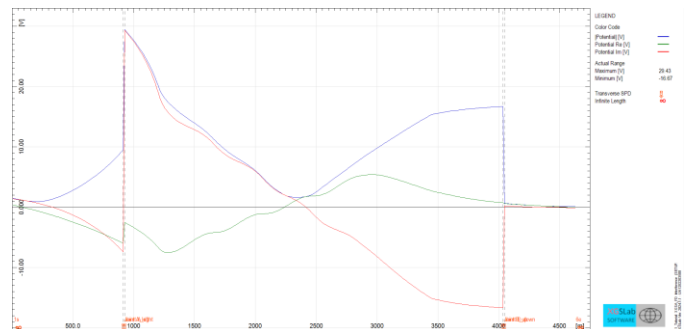

Induced potential on the pipeline (blue magnitude, green real, red imaginary)

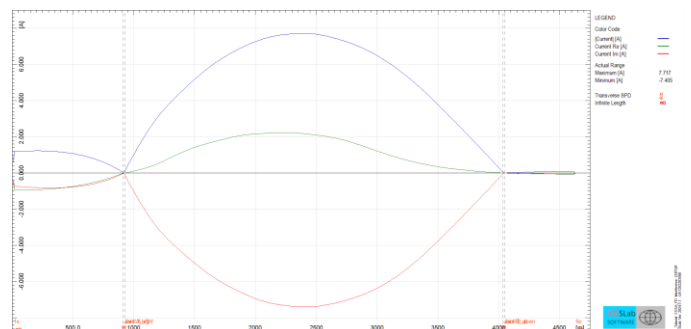

Induced current on the pipeline (blue magnitude, green real, red imaginary)

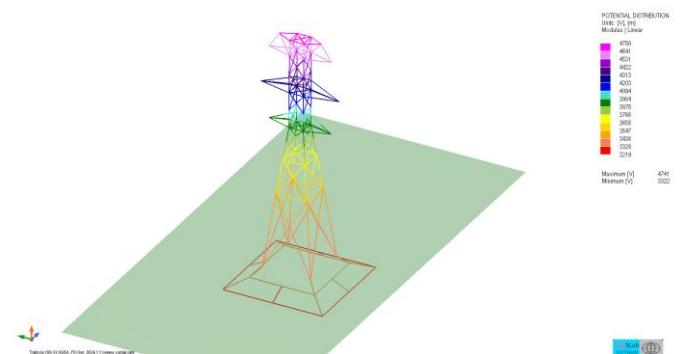

Potential - HV lattice

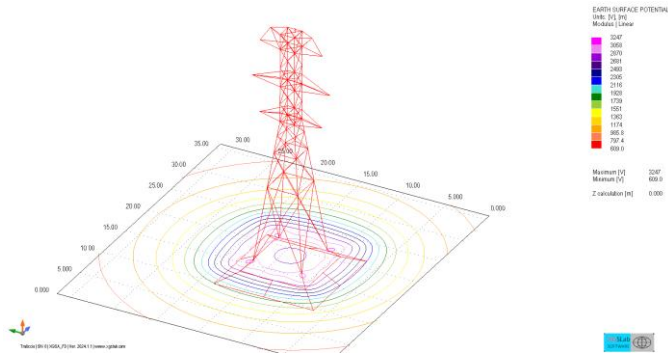

Earth surface potential – HV lattice – Contours option

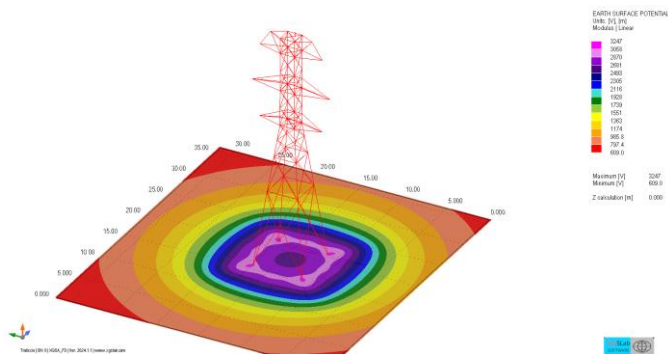

Earth surface potential – HV lattice – Colors option

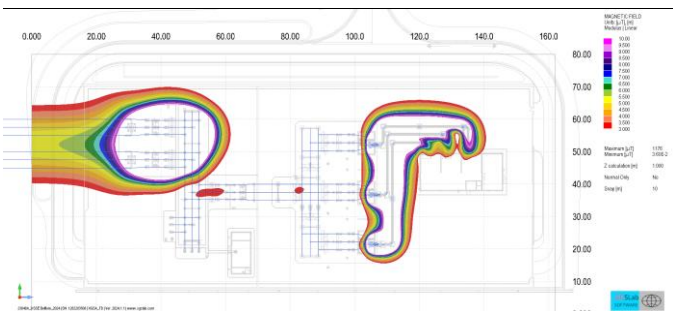

Magnetic field on horizontal surface – Substation – Colors option

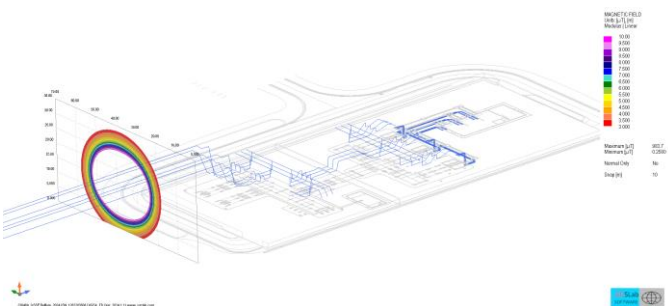

Magnetic field on vertical surface – Substation – Colors option

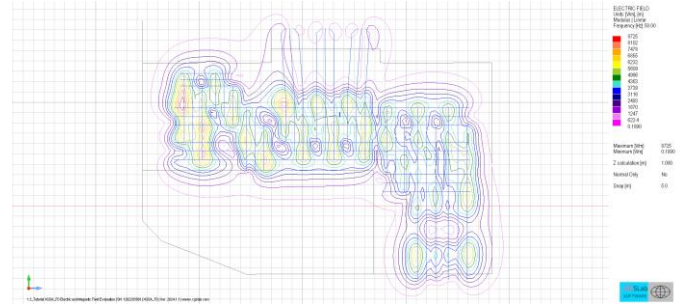

Electric field on horizontal surface - Substation - Contours option

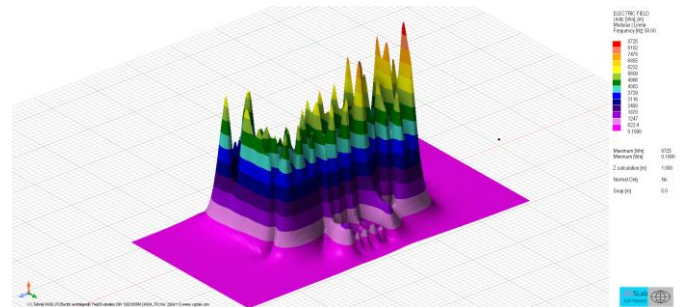

Electric field on an horizontal surface - Substation - Colors option

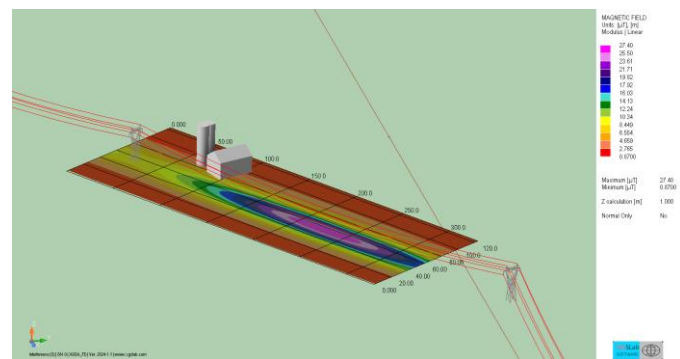

Magnetic field on an horizontal surface – Power line - Colors option

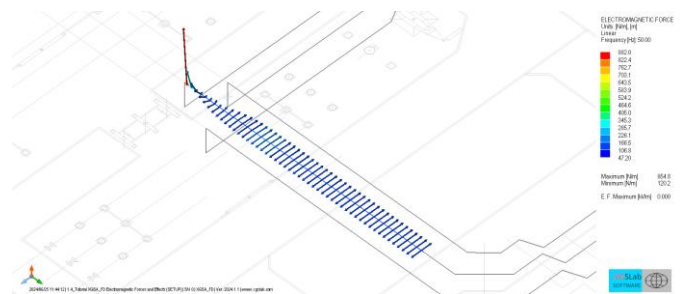

Electromagnetic force along conductors - Substation

MAIN FEATURES (in addition to GSA_FD)

- Analysis of overhead (and/or underground) systems of any shape, with choice of the total number of elementary sources
- Possibility to analyse up to 999 distinct overhead (and/or underground) electrodes on the same calculation
- Possibility to consider energization with sources, that are conductors with forced potentials or leakage currents and longitudinal currents
- Possibility to consider additional longitudinal and transverse impedances or Surge Protective Devices
- Possibility to calculate electromagnetic force and to analyse their effects on busbars and supports
- Possibility to analyse overhead straight or catenary conductors of single or bundle conductors
- Possibility to analyse the power losses and the radiofrequency interference related to the corona effects



SYSTEM ANALYSIS in the TIME DOMAIN

XGSA_TD can be used for advanced electromagnetic interference and fields analysis of aboveground and underground systems in the time domain taking into account transients with maximum bandwidth up to about 100 MHz and is commonly used for the evaluation of interference in transient conditions. This module can also calculate the electromagnetic force on conductors.

XGSA_TD includes the tools SRA and SSA for soil resistivity analysis, soil seasonal analysis and multilayer soil modelling.

XGSA_TD is highly appreciated for its power and accuracy and used by both Universities and Industries.

GENERAL DESCRIPTION

XGSA_TD is a powerful module which extends the XGSA_FD application field to the time domain.

In this regard, XGSA_TD uses the so called "frequency domain approach". This approach is rigorous and allows considering the frequency dependence of soil parameters.

XGSA_TD can be applied to transients with maximum bandwidth up to about 100 MHz, and then can be used for switching transients, lightning and also in fault transients in GIS.

As for XGSA_FD, also XGSA_TD is a multipurpose software and its application field includes power systems, grounding, interference and lightning analysis. For instance, XGSA_TD can evaluate the distribution of the lightning stroke currents along lightning protection system (underground and overhead components) and also the related potential, electromotive force and leakage current distributions in the time domain.

XGSA_TD is also useful to calculate magnetic and electric fields due to underground or overhead electrodes in the time domain.

INPUT DATA (in addition to XGSA_FD)

- Maximum calculation frequency used 1, 10 or 100 MHz (1 MHz for switching transients, 10 MHz for lightning, 100 MHz for fast transients like fault transients in GIS)
- Parameters of the normalized standard transient function (Double Exponential, Pulse or Heidler functions)
- Samples or arbitrary normalized transient functions or recorded transient (copied from EXCEL® files)
- Number of critical frequencies (with default or customized selection)

OUTPUT RESULTS

XGSA_FD provides the time domain distribution and the frequency spectrum of the input transient (with linear and Log scale plot).

XGSA_TD results are as for XGSA_FD but in the time domain. Calculations of earth potentials, touch and step voltages, electric and magnetic fields are possible along lines. XGSA_TD includes an option to export frequency dependent self and mutual impedances to EMTP® or ATP® in order to simulate with a rigorous model the dynamic behavior of large grounding systems during electromagnetic transients.

It is possible to represent:

- The time domain distribution of leakage current, longitudinal current, potential, electromotive force and complex power in each point on the electrodes with 1D representation
- The time domain distribution of earth potentials, touch and step voltages, electric and magnetic fields in each point of a line calculation
- The distribution of earth potentials, touch and step voltages, electric and magnetic fields along an entire line calculation at a fixed time
- The animation of the time domain distribution of earth potentials, touch and step voltages, electric and magnetic fields along an entire line calculation
- The time domain distribution of electromagnetic forces in each point on the electrodes with 1D representation

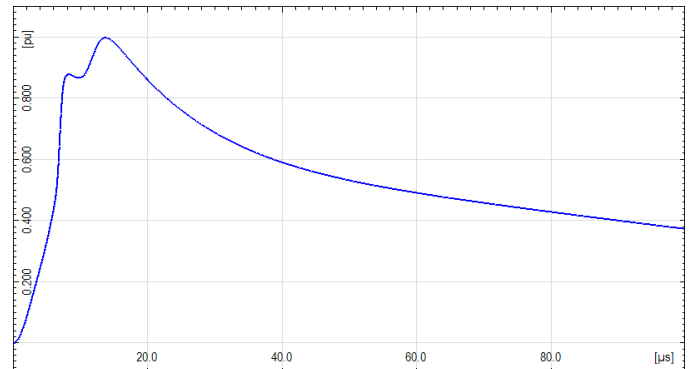

Normalized double peak transient in the time domain - Linear scale

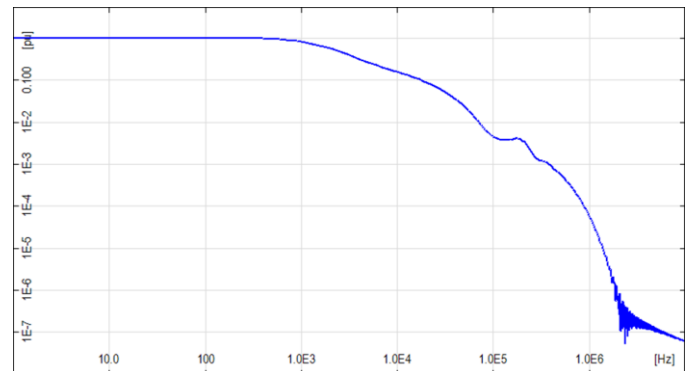

Normalized magnitude spectrum - Log scale

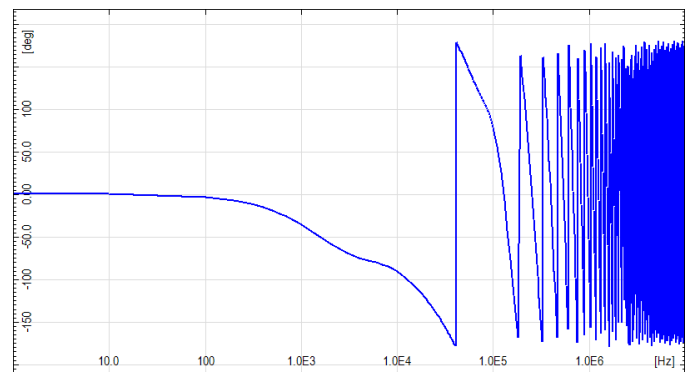

Normalized phase spectrum - Log Linear scale

MAIN FEATURES

As for XGSA_FD but in the time domain.

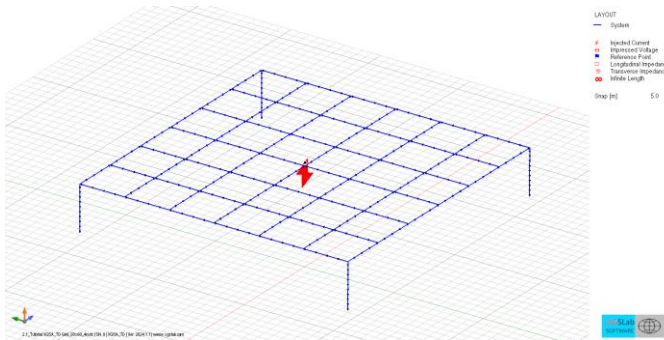

Grounding system layout and current injection point

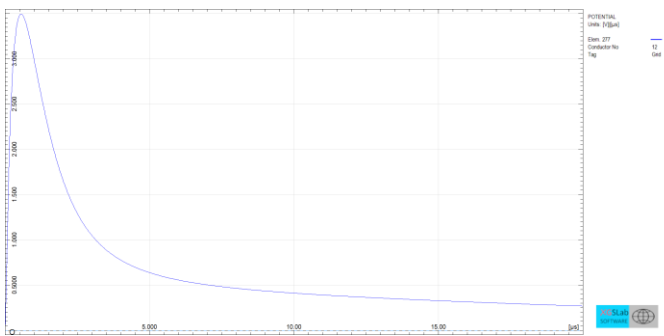

TGPR in the time domain (Linear scale)

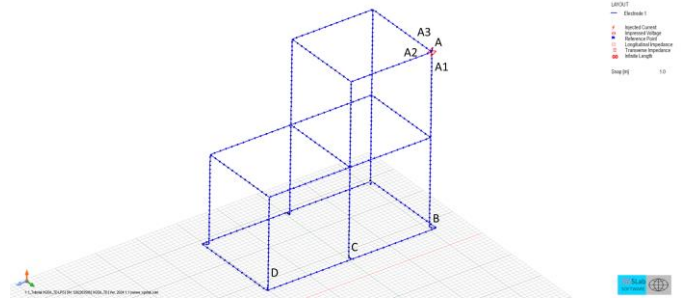

Building LPS and lightning current injection point

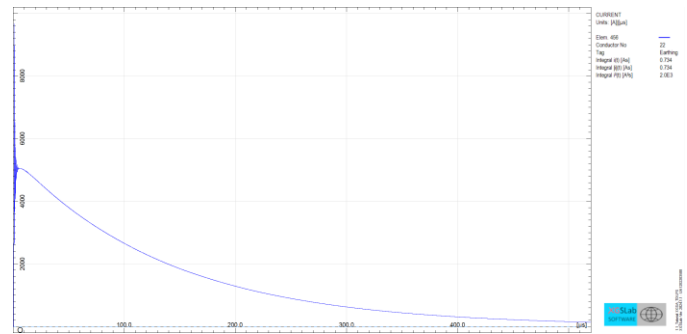

Current in the time domain in a down conductor (Linear scale)

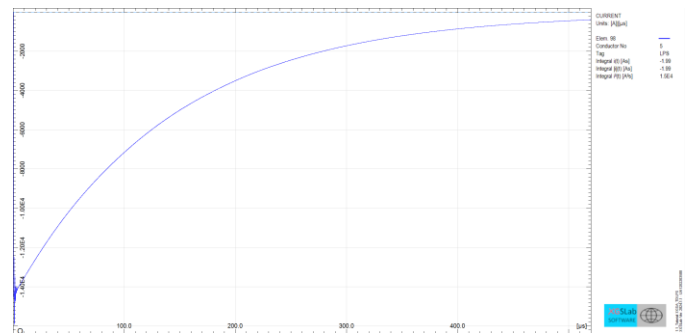

Current in the time domain in an air termination conductor (Linear scale)



SINT Srl

ENGINEERING CONSULTING AND SOFTWARE



NETWORK SOLVER

NETS can be used for analysis of multi-conductor and multi-phase full meshed networks also in cases of multiple connection to earth (when the sequence components method cannot be applied) and is commonly used for the evaluation of current distribution in fault and steady state conditions in cables and power lines, including the evaluation of current along screens, armors and overhead earth wires.

NETS can be used also for the evaluation of fault current distribution and is commonly used for the split factor calculation in general conditions.

NETS can be used also for electromagnetic interference analysis of aboveground and underground systems at power frequency, and is commonly used for the evaluation of interference between power lines or cables or railways and pipelines.

NETS is highly appreciated for its power, accuracy and flexibility.

GENERAL DESCRIPTION

NETS is a computation code for the solution of full meshed multi-conductor and multi-phase underground and/or overhead networks in the frequency domain. The application range is limited to the model accuracy of transformers (up to 1 kHz) cables (up to 1 kHz) and lines (up to 10 kHz).

NETS is based on the phase components method (and then on Kirchhoff laws) and graphs theory for multi-conductor and multi-phase systems. The phase components method is general and overcomes the limits of the classic sequence components method and can be used to represent power systems as multi-conductor networks enabling the consideration of non-symmetrical systems also in presence of multiple grounding circuits. The maximum number of conductors (and so of ports for a single cell side) is 26, so enough to represent most network components (the simulation of 6 cables with core, screen and armour requires 18 conductors).

The network components (sources, ideal voltage generators, ideal current generators, loads, transformers, lines, single core and multicore cables, hybrid links, impedances, switches, faults ...) are represented with multi-port cells and the connection between cells is obtained by means of multi-port buses. The grounding systems (substation grids, tower footings ...) can be specified in an arbitrary way.

NETS calculates parameters of lines and cables starting on data normally available in commercial data sheet. NETS calculates self and mutual impedances and admittance for all conductors using accurate formulas and taking into account the earth resistivity and permittivity.

NETS calculates parameters of single-phase or three-phase two or three-winding transformers starting on data usually available in commercial data sheet.

NETS includes a converter from the sequence domain to the phase domain. This tool can convert a sequence impedances matrix to a phase impedance matrix.

NETS can be used to solve symmetrical or non-symmetric, balanced or unbalanced transmission and distribution networks in steady state or fault conditions.

In particular, NETS can be used for the calculation of the fault current distribution in power networks and between power circuits and earth.

Moreover, NETS is a powerful tool for the evaluation of current distribution and electromagnetic interference in case of railways corridors.

An accurate knowledge of the fault current distribution is crucial in grounding, mitigation to reduce interference on communication circuits and pipelines, power system protections calibration and coordination, neutral grounding resistor sizing and many others applications.

INPUT DATA

- The input data interface has been designed in order to require a minimum and simple set of information
- Circuit Layout (buses and cells distribution and connection)
- Data for generic cells (e.g. cell class, cell type, ports numbers, and for each port, phase from A to Z and parameters like voltages, currents and impedances)
- Data for line and/or cable cells (as a generic cell and in addition, line or cable length, earth resistivity, operative temperature and, for each port, library code and cross section layout information). Line library and cable library include all additional data required by line and cable cells
- Data for hybrid cells. Similar to line and cable cells but including conductors like pipes, rails, counterpoises ...
- Data for transformer cells (as a generic cell and in addition, library code, neutral impedances, and for each port, longitudinal impedances). Transformers libraries include all additional data required by a cell two or three-windings transformer

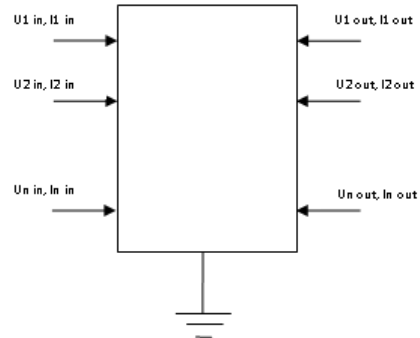

Multi-port Cell

OUTPUT RESULTS

- Current on each port of each cell
- Current to earth in each connection to earth
- Potential on each port of each cell
- Potential in each connection to earth
- Power flow on each port of each cell
- Current distribution along lines and cables
- Potential distribution along lines and cables
- EMF distribution along lines and cables
- Results are available in numerical and graphical form

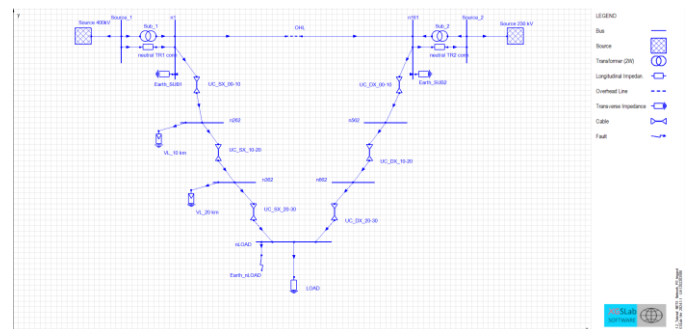

Network layout

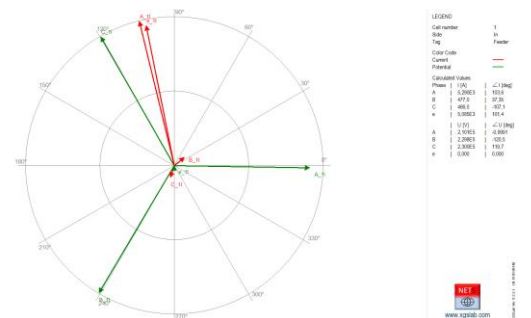

Phasor diagram (or Fresnel diagram) of potentials and currents at a cell side



SINT Srl

ENGINEERING CONSULTING AND SOFTWARE

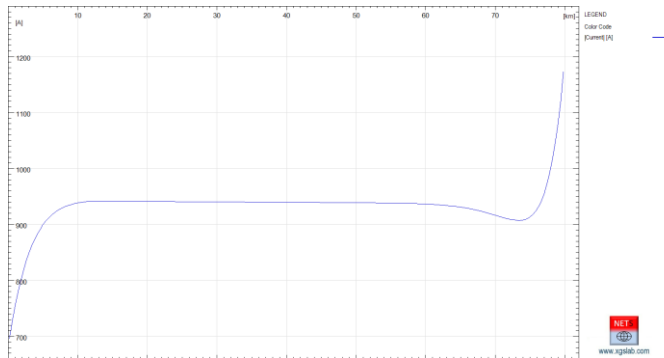

Current along an OHEW – Magnitude - Linear scale

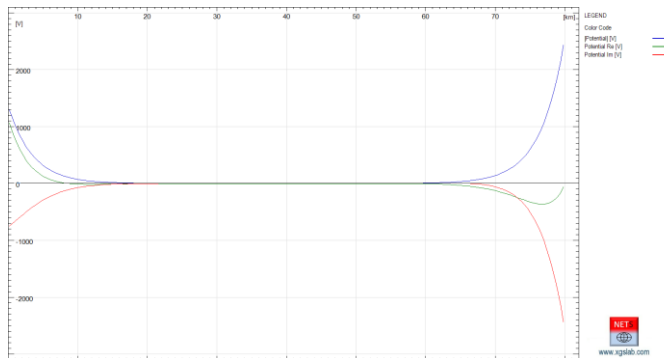

Potential along an OHEW - Magnitude, real and imaginary parts

MAIN FEATURES

- Calculation model based on the phase components method and graphs theory for multi-conductor and multi-phase systems
- Automatic debug of data before calculation
- Automatic recognition of the connections between cells and buses and automatic definition of linkage (or boundary) equations

- Arbitrary number of buses and cells (the number is limited only by the hardware constraints)
- Cells class 1: multi-port cells with only a group of ports (input) used to represent sources, ideal voltages or currents sources, transverse impedances or faults
- Cells class 2: multi-port cells with two group of ports (input and output) used to represent overhead lines, overhead or underground single core and multicore cables, hybrid links, two-windings transformers, longitudinal impedances or switches
- Cells class 3: multi-port cells with three group of ports (input and two output) used to represent three-windings transformers
- Buses: multi-port buses with an arbitrary number of group of ports
- Automatic calculation of cables, lines and transformers parameters
- Cable cells can represent single core or pipe type cables. Each single cable can include core, screen and armour
- A single cell can represent a long line or a long cable or a single span or part of it. The detail level in the model can be decided by the User
- Two-winding transformer cells can represent single-phase or three-phase two-winding transformers. Three-phase transformers can have connections Y, D or Z, any group number (0 to 11), any kind of neutral state (insulated, grounded, and generally grounded with an impedance to earth) and neutral distributed or not
- Three-winding transformer cells can represent single-phase or three-phase three-winding transformers. Three-phase transformers can have connections Y or D, any group number (0 to 11), any kind of neutral state (insulated, grounded, and generally grounded with an impedance to earth) and neutral distributed or not
- Longitudinal impedance cells can represent interruptions of all or single phases
- Transversal impedances cells can represent any kind of short circuit between phases and/or to earth
- The phase impedances necessary to represent components like sources, longitudinal or transverse impedances can be calculated starting from the corresponding sequence impedances matrix using the sequence to phase converter tool
- Libraries with commercial data for lines, single core and multicore cables, conductors and transformers
- Possibility to choose the language (English, German, French, Italian, Spanish, Portuguese)



SINT Srl

ENGINEERING CONSULTING AND SOFTWARE



LIGHTNING SHIELDING

SHIELD can be used for the lightning shielding design using the Rolling Sphere or Eriksson methods and can be used for the evaluation of the protection against direct lightning strokes of structures of any height or up to 60 m height in case of relevant protrusions. SHIELD is highly appreciated for its power, accuracy and flexibility.

GENERAL DESCRIPTION

SHIELD is a powerful full 3D graphical application for the evaluation of the protection of structures from direct lightning strokes using the Rolling Sphere and the Eriksson methods. SHIELD is based on a numerical model that consider vertical direct lightning strokes, and is then suitable for structures of any height or up to 60 m height in case of relevant protrusions.

The Rolling Sphere Method is considered by many standards (EN, IEEE, NFPA, AS ...) and is an universal method for shielding design, and particularly recommended for complex geometry.

Alternative mesh methods like the protection angle or mesh method are suitable for simple-shaped buildings or for buildings where plane surfaces are to be protected.

The Rolling Sphere Method can be applied to the structure to be protected. In such case, SHIELD can identify the parts of the structure exposed to a direct lightning stroke, that are the points where is more effective to install the air termination system.

Then the Rolling Sphere Method can be applied to air termination + down conductor system. In such case SHIELD generates a 3D surface corresponding to the protected volume.

The protected volume is then superposed to the structure to be protected. The parts of the structure to be protected that protrudes over this surface are not protected.

The Rolling Sphere Method has been implemented taking into account a numerical models based on a geometrical scan over a calculation grid, suitable for structures of any height or up to 60 m height in case of relevant protrusions.

The numerical model will consider essentially vertical lightning strokes.

When the Eriksson Method is set, SHIELD generates the collection area of air termination + down conductor system and structure to be protected.

The lightning protection system is effective when collection area of air termination + down conductor system includes collection area of structure to be protected.

The User can modify the lightning protection system and generate again the protected volume or collection areas. This iterative process allows to get an effective shield.

Lightning shielding is an increasing important topics. In many areas the flash density is growing and on the other side the values to be protected (people, buildings, systems ...), are also increasing. A good lightning shielding design is the first step for a good lightning protection system installation.

INPUT DATA

- The input data interface has been designed in order to require a minimum and simple set of information
- Layout of the structure to be protected
- Layout of air termination + down conductor system
- Calculation Method (Rolling Sphere or Eriksson)
- Data for calculation of the surge impedance and peak of the return stroke current
- Striking distance (entered or calculated)

OUTPUT RESULTS

- Surge impedance
- Peak of the return stroke current
- Striking distance
- Failure rate
- Parts of the structure to be protected exposed to a direct lightning stroke
- Protected volume (calculated with the Rolling Sphere method)
- Protected volume (calculated with the Rolling Sphere method) considering a given safety margin distance
- Collection areas (calculated with the Eriksson method)
- Results are available in numerical and graphical form

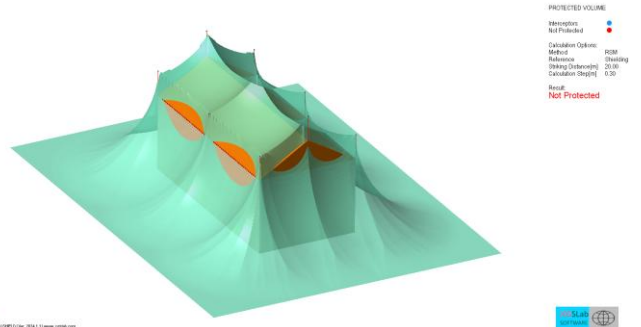

Protected Volume calculated with the Rolling Sphere method – Simple case

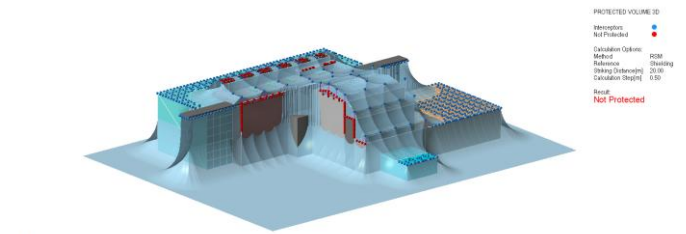

Protected Volume calculated with the Rolling Sphere method – Hydro Power Plant

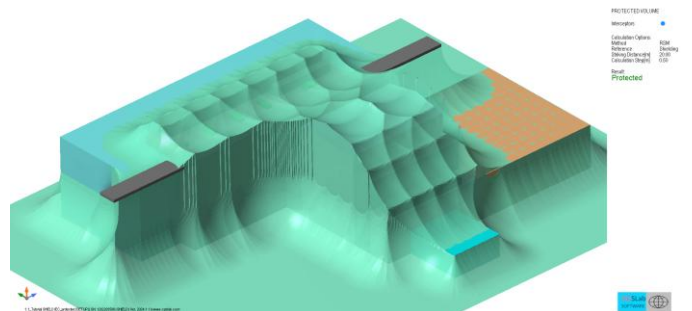

Protected Volume calculated with the Rolling Sphere method – Hydro Power Plant

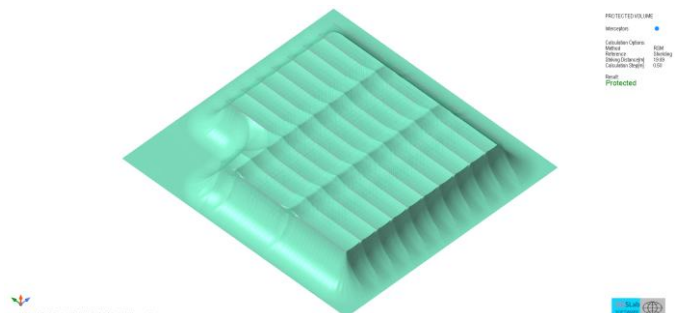

Protected Volume calculated with the Rolling Sphere method – Substation



SINT Srl

ENGINEERING CONSULTING AND SOFTWARE

MAIN FEATURES

- Calculation method based on Rolling Sphere and Eriksson methods
- Rolling Sphere method implemented using numerical model that consider vertical direct lightning strokes, and is then suitable for structures of any height or up to 60 m height in case of relevant protrusions
- Possibility to consider International (IEC 62305-3:2024), European (EN 62305-3:2025) and American (IEEE Std 998-2012) standards
- Surge impedance calculation (according to IEEE Std 998-2012)
- Possibility to import grid layout from "dxf or dwg" files (2D or 3D segments)
- Automatic debug of data before calculation
- Analysis of lightning protection systems of any shape (masts, horizontal wires, catenary wires ...)
- Possibility to represent results using OpenGL vector graphics (viewer)
- Possibility to create data input using OpenGL vector graphics (CAD)
- Possibility to export layout data and results in "dxf or dwg" file
- Possibility to export graphic outputs to other WINDOWS® applications
- Possibility to choose the language (English, German, French, Italian, Spanish, Portuguese)

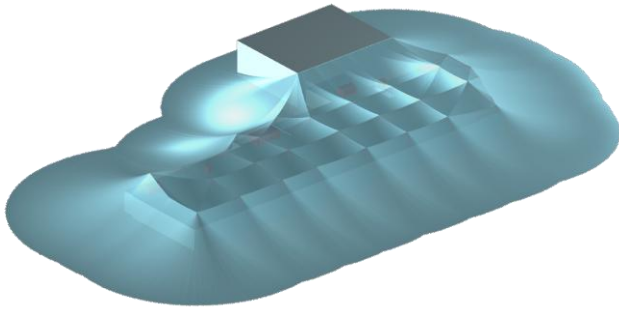

Protected Volume calculated with the Rolling Sphere method – Industrial plant

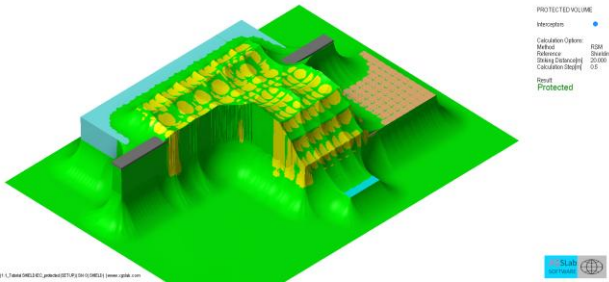

Protected Volume represented using a safety margin 5 m

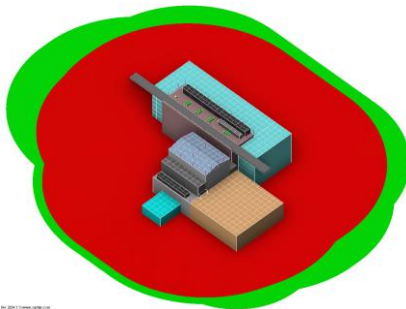

Collection areas calculated with the Eriksson method

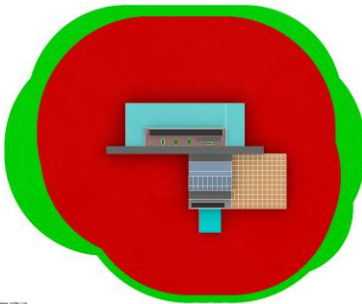

Collection areas calculated with the Eriksson method



SINT Srl

ENGINEERING CONSULTING AND SOFTWARE



LIGHTNING SHIELDING ADVANCED

SHIELD_A can be used for the lightning shielding design using the Rolling Sphere method and can be used for the evaluation of the protection against direct lightning strokes of special structures of any height and shape.

SHIELD_A is highly appreciated for its power and accuracy.

GENERAL DESCRIPTION

SHIELD_A is a powerful full 3D graphical application for the evaluation of the protection of structures from direct lightning strokes using the Rolling Sphere method. SHIELD is based on analytical model that consider vertical and lateral direct lightning strokes, and is then suitable for special structures of any height and shape.

Unlike SHIELD, SHIELD_A can also consider structures with significant protrusions, for instance wind towers, and has been developed mainly for lightning specialists. In essence, SHIELD_A was developed for all applications where SHIELD cannot be used, and is intended to be complementary to SHIELD.



SINT Srl

ENGINEERING CONSULTING AND SOFTWARE

PRODUCT COMPARISON CHART

	GSA	GSA_FD	XGSA_FD	XGSA_TD	NETS	SHIELD	SHIELD_A
Electromagnetic Fields Theory Based	✓	✓	✓	✓			
Multi-conductor and Multi-phase Circuits Theory Based					✓		
Electro Geometric Model Design Theory Based						✓	✓
IEC, EN and IEEE Standards	✓	✓	✓			✓	✓
Under Ground Systems	✓	✓	✓	✓	✓		
Above Ground Systems			✓	✓	✓		
Frequency Domain Calculation		✓	✓		✓		
Time Domain Calculation with standard transients (Double Exponential, Pulse or Heidler)				✓			
Time Domain Calculation with arbitrary or recorded transients (copied from EXCEL® files)				✓			
Soil Resistivity Analysis suitable for both Wenner and Schlumberger measures	✓	✓	✓	✓			
Uniform Soil Model	✓	✓	✓	✓			
Multilayer Soil Model with an arbitrary layers number	✓	✓	✓	✓			
Multizone Soil Model		✓	✓				
Soil Seasonal Analysis	✓	✓	✓	✓			
Soil Parameters Frequency Dependence		✓	✓	✓			
Up to 999 Distinct Electrodes	✓	✓	✓	✓			
Energization using both Multiple Current and Voltage Sources		✓	✓	✓			
Energization with Conductors with forced Potentials or Leakage Currents and Longitudinal Currents			✓				
Layout Graphical Input from "dxf or dwg" and Export to "dxf or dwg" files	✓	✓	✓	✓			
Results Export to "kml or kmz" files	✓	✓	✓				
Integrated Drawing Tool	✓	✓	✓	✓	✓		
Automatic Nodes (or Buses) Recognition		✓	✓	✓	✓		
Automatic Conductor Division and Conditioning		✓	✓	✓			
Resistive Coupling	✓	✓	✓	✓			
Capacitive Coupling		✓	✓	✓			
Inductive Coupling		✓	✓	✓			
Self Impedance		✓	✓	✓			
Additional Longitudinal or Transverse Impedances		✓	✓	✓			
Surge Protective Devices			✓				
Screened Conductors		✓	✓	✓			
Catenary and Bundle Conductors			✓	✓			
Propagation Effects		✓	✓	✓			
Calculation of Potentials and Touch and Step Voltages on and below the Soil Surface	✓	✓	✓	✓			
Calculation of Magnetic Fields on and above the Soil Surface		✓	✓	✓			
Calculation of Electric Fields on and above the Soil Surface			✓	✓			
Calculation of Electromagnetic Forces on and above the Soil Surface			✓	✓			
Corona Effects (Power Losses and Radiofrequency Interference)			✓				
Multi-conductor / Multi-phase Systems					✓		
Overhead Lines / Overhead and Underground single core and multicores Cables					✓		
Full 3D Protected Volume Calculated using the Rolling Sphere Method						✓	✓
Collection Area Calculated using the Eriksson Method						✓	



COMPARING GSA TO GSA_FD

The following table summarizes the main assumptions on which GSA and GSA_FD modules are based.

Aspects taken into account	GSA	GSA_FD
Resistive coupling	Yes	Yes
Capacitive coupling	No	Yes
Self Impedance	No	Yes
Mutual Impedance	No	Yes
Soil parameters	ρ	$\rho, \epsilon = f(\omega)$
Propagation law	$1/r$	$e^{-\gamma r}$

The following diagram represents the application domain of the two modules. The highlighted central area indicates the usual condition at power frequency. The diagram has been obtained from a parametric analysis using square well-meshed copper grids energized with a current injected in a corner. The analysed parameters were the grid diagonal "D", the soil resistivity and the frequency. In its application dominion as defined by the red solid line, the error made by GSA in the GPR and touch voltages calculation is lower than about 10%.

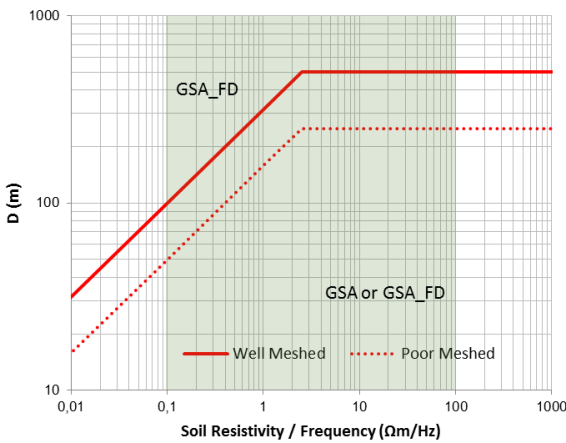

Application domain of GSA and GSA_FD - Log scale

In practice, in case of well-meshed grids, application limits of GSA can be defined as a function of the wavelength of the electromagnetic field in the earth as follows:

$$\lambda = 3162 \sqrt{\frac{\rho}{f}}$$

where λ (m) = wavelength, ρ (Ω m) = soil resistivity and f (Hz) = frequency.

The previous diagram indicates that GSA can be used if " $D < \lambda/10$ ". This result is in agreement with the simultaneity concept of Albert Einstein. GSA also requires " $D < 500$ m" as reasonable limit. The application limits will be lower if the grid shape is not regular, if the meshes are sparse and if the grid is made of steel or other high resistivity metal. In all these cases, the limit related to poor-meshed grids as defined by the red dashed line should be considered.

The following three figures show the earth surface potential distribution calculated by applying GSA and GSA_FD to a 200 m x 200 m grid with the same injected current, the same frequency (100 Hz), the same injection point (marked with an arrow) and different soil resistivities.

The qualitative difference between results is evident. In general, GPR and impedance to earth tend to grow whether self and mutual impedance are taken into account. High frequency or low soil resistivity can make this difference even more evident.

Of course, a difference in the earth surface potential distribution corresponds to a difference in touch and step voltage distribution.

In brief, in grounding system analysis at power frequency, GSA can be used in many practical situations but it tends to underestimate the results if the grid size is greater than one tenth of the wavelength of the electromagnetic field, while GSA_FD may be applied in all conditions.

At high frequency, GSA can be applied only to grids with a maximum size of about some tens of meters. In general, at high frequency GSA_FD should be used.

In electromagnetic interference analysis, GSA and GSA_FD can be used respectively for only resistive and resistive + capacitive + inductive coupling evaluation.

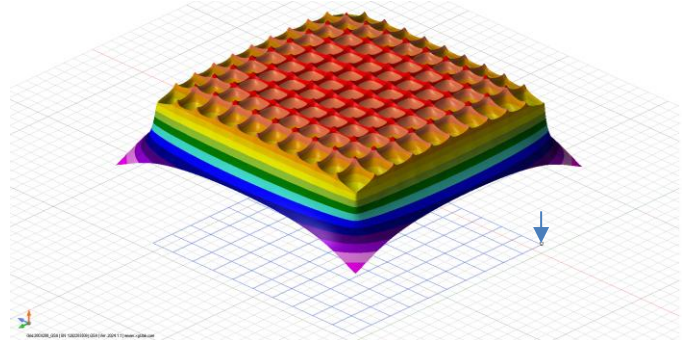

Earth surface potential - GSA or GSA_FD with high soil resistivity

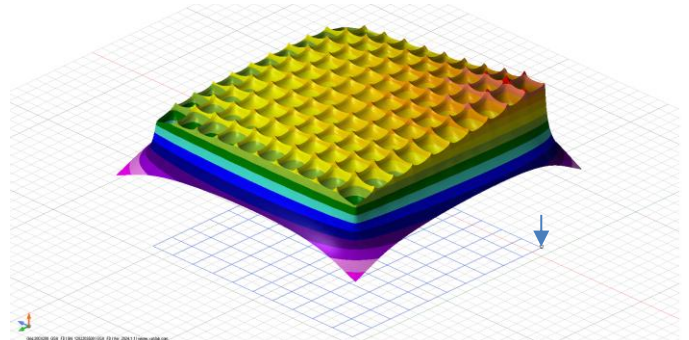

Earth surface potential - GSA_FD with medium soil resistivity

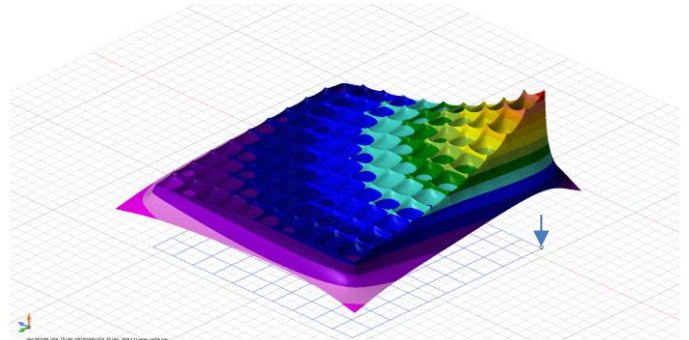

Earth surface potential - GSA_FD with low soil resistivity

After these conclusions a question could arise: why not just GSA_FD?

The answer is simple but not trivial.

GSA requires an easier data entry, accept rough layouts, is cheaper and faster than GSA_FD and requires fewer computer resources.

GSA_FD requires additional information about the topology of the conductors system and in order to calculate their self and mutual impedances and a well finished layout.

Moreover GSA_FD requires more experience in the evaluation of results.

If GSA cannot be used, GSA_FD is the right solution.



SINT Srl

ENGINEERING CONSULTING AND SOFTWARE

COMPARING XGSA_FD TO XGSA_TD

XGSA_FD is based on the same model of GSA_FD but extended to overhead conductors. The application limits of XGSA_FD can be assumed from DC to about 100 MHz. XGSA_FD greatly expands the application field of XGS and makes it a real laboratory for engineering applications and for research.

XGSA_FD is an irreplaceable tool when conductors are partly overhead and partly underground. This situation is usual in electromagnetic fields evaluation (where sources may be underground cables or overhead wires) or interference analysis (where often the inductor is overhead and the induced is underground).

Anyway XGSA_FD operates to a single frequency.

XGSA_TD can calculate the response in the time domain of a conductors network energized with current or voltage transients.

As known, the methods to calculate the transient behaviour of conductors network in the time domain can be divided into two main categories: those based on the calculation of the solution directly in the time domain and those based on frequency domain calculations and then using the forward and inverse Fast Fourier Transforms.

Methods of the first category require low frequency and quasi-static approximations and in addition do not allow considering the frequency dependent characteristics of the grounding system.

Methods of the second category use an electromagnetic field approach for the calculation of the response of the grounding system in a wide range of frequencies and have a good accuracy because they are based strictly on the principles of electromagnetism. On the other hand, in these methods, a system of equations has to be solved for every particular frequency, and a large number of discrete frequency points over the frequency band are chosen to satisfy the frequency sampling theorem.

XGSA_TD is based on the second category methods and uses XGSA_FD as solver in the frequency domain. Then the application limits of XGSA_TD can be assumed as the same of XGSA_FD and in particular the maximum bandwidth of the input transient should be lower than 100 MHz.

This means that XGSA_TD can consider transient input as switching transients, standard lightning currents and also fault transients in GIS.

The simulation of lightning represents the most typical application of XGSA_TD.

The lightning current can be simulated by using the standard short stroke wave form IEC 62305: first positive; first negative; subsequent negative.

With the direct Fast Fourier Transform, the time domain input transient is decomposed in the frequency domain.

In the following figures the normalized wave shape of the subsequent negative standard lightning current and their normalized spectrum. The spectrum can be neglected when normalized values are lower than about 10^{-3} - 10^{-4} . The standard lightning bandwidth is lower than a few MHz also for the fastest lightning, the subsequent negative ones.

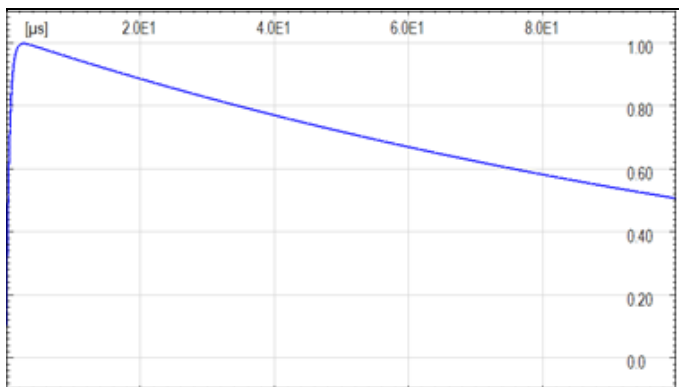

Normalized subsequent negative standard lightning - Linear scale

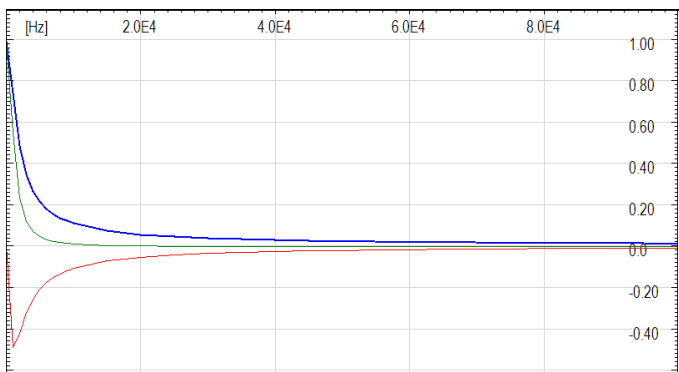

Normalized magnitude spectrum - Magnitude, real and imaginary parts - Linear scale

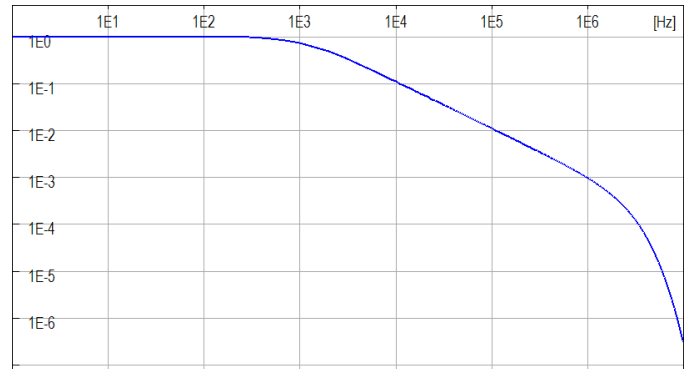

Normalized magnitude spectrum - Log scale

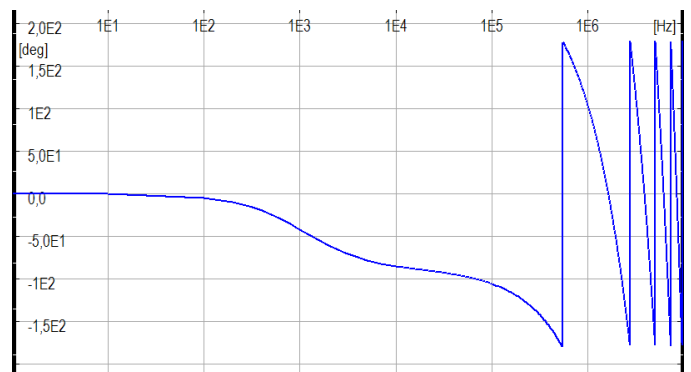

Normalized phase spectrum - Log Linear scale

After the calculation in the frequency domain (taking into account a suitable number of representative frequencies in order to limit the calculation time), the response in the time domain is obtained with interpolation of results and the inverse Fast Fourier Transform.

The evaluation of lightning effects is important in many practical applications. For instance, current generated by a stroke flows in the LPS conductors and dissipates in the soil. The electric and magnetic field generated by such high voltages and currents can cause internal discharges, fires and explosions, may cause damage of equipment and buildings and may be dangerous for people.

In conclusion, XGSA_TD uses XGSA_FD as a calculation engine and Fast Fourier Transforms in order to move from time to frequency domain and vice versa.

XGSA_TD includes the module FFA (Fast Fourier Analysis). FFA can calculate the FFT of typical transients (double exponential pulse and Heidler functions) and also of recording samples.



SINT Srl

ENGINEERING CONSULTING AND SOFTWARE

UNIFORM, MULTILAYER AND MULTIZONE SOIL MODELS

The choice of the soil model is crucial in electromagnetic simulations of systems close to the soil surface and in particular in the grounding systems analysis. There is much literature about the criteria to set an appropriate soil model which can be used to predict the performances of a grounding system. XGS allows to use uniform, multilayer and multizone soil models.

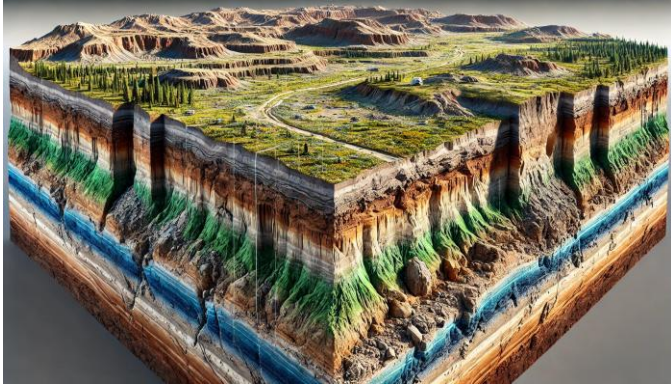

A typical soil cross section including ground water

A uniform soil model should be used only when there is a moderate variation in apparent measured resistivity both in vertical and horizontal direction but, for the majority of the soils, this assumption is not valid. A uniform soil model can also be used at high frequency because in that case, the skin effect limits the penetration depth of the electromagnetic field to a few meters and so, the soil resistivity of the depth layers do not affect the results.

The soil structure in general changes both in vertical and horizontal direction and the presence of ground water further complicates things. The vertical changes are usually predominant on the horizontal ones, but about this aspect, is essential to consider also the grounding system size.

In case of small grounding systems (maximum size up to a few hundred meters), soil model is not significantly affected by horizontal changes in soil resistivity and usually a multilayer soil model is appropriate. The layer number depends on the soil resistivity variations in vertical direction and three, four or five layers can be sufficient for most cases. Sometime, in order to consider seasonal effects on soil model like frozen soil, a bigger layers number can be necessary.



Parameters evaluation for a four layers soil model - Linear scale

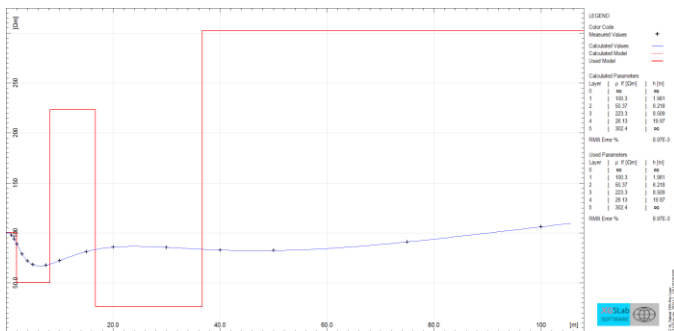

Parameters evaluation for a five layers soil model - Linear scale

In case of grounding systems of intermediate size, soil model is affected by both horizontal and vertical changes in soil resistivity and usually an equivalent double or triple layer soil model is appropriate. This is the most important case in practical applications.

In case of large grounding systems (maximum size over a few kilometres), soil model is significantly affected by horizontal changes in soil resistivity and usually a multizone soil model is appropriate. The zones number depends on the systems size and soil resistivity variations in horizontal direction.

In future release, XGS will allow the use of a new soil model called Multiregion, where each zone can be characterized with a multilayer model. The Multiregion model will be based on a hybrid analytical and statistical model and can be applied in general to large and very large systems.

XGS includes two powerful tools, SRA (Soil Resistivity Analysis) and SSA (Soil Seasonal Analysis).

SRA is able to calculate a uniform or multilayer soil model starting from a set of soil resistivity measurements using Wenner or Schlumberger arrangements.

In order to avoid unappropriated usage, the maximum number of layers that SRA can calculate has been set 20 (despite that, the program can use an arbitrary number of layers).

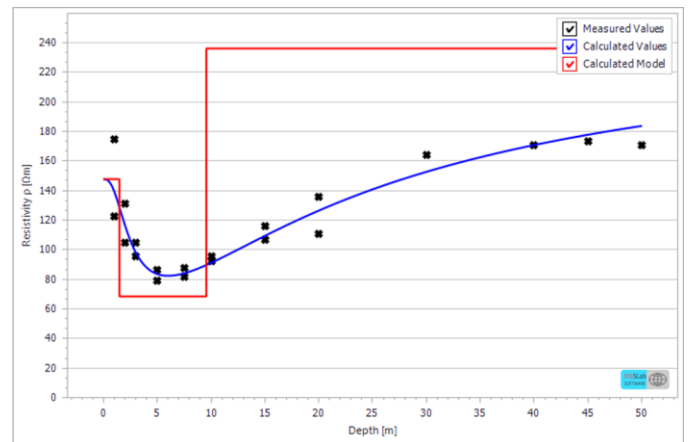

SRA Input and Output

SRA is very powerful and versatile and is based on a sophisticated optimization algorithm. However, it is important to consider that the soil model calculated by SRA is based on measurements referred to a specific day or anyway a short period of the year and moreover on the climatic condition history.

Then, the soil model is valid only around a specific date.

But what about the soil model in other days or other seasons?

The soil resistivity depends on many factors and about seasonal effects, primarily by soil temperature and secondarily by soil moisture.

SSA can calculate how the soil model changes over the seasons taking into account soil temperature and moisture calculated based on local climatic data.

The seasonal effects affect grounding system's resistance to earth and resulting touch and step voltages. A grounding system which satisfies the safety standards with the soil properties calculated from soil resistivity measurements, could become unsafe in another season. This aspect is important in cold regions.

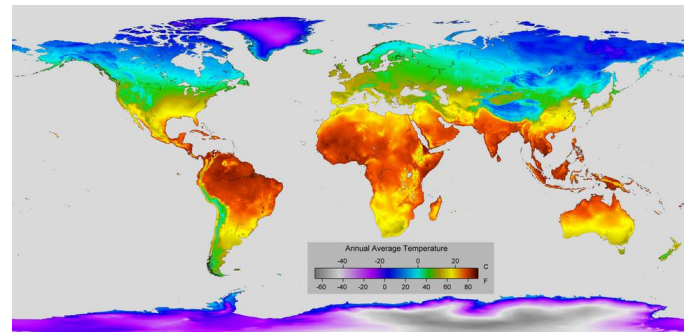

Annual average temperature World map

SSA is also based on very sophisticated algorithms, yet the input data requirement is limited to readily available data.

Furthermore, SSA is able to perform daily scans throughout the year to identify the day with the worst conditions.

At the end of the calculation, SSA displays the initial soil model and the soil model modified for seasonal variations in soil temperature and moisture.

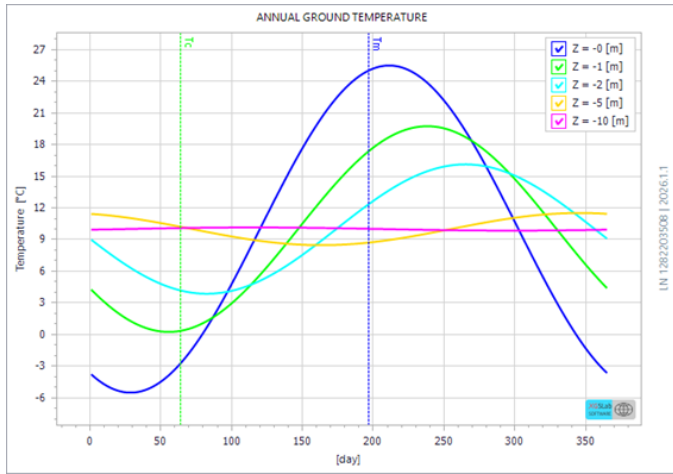

Annual ground temperature

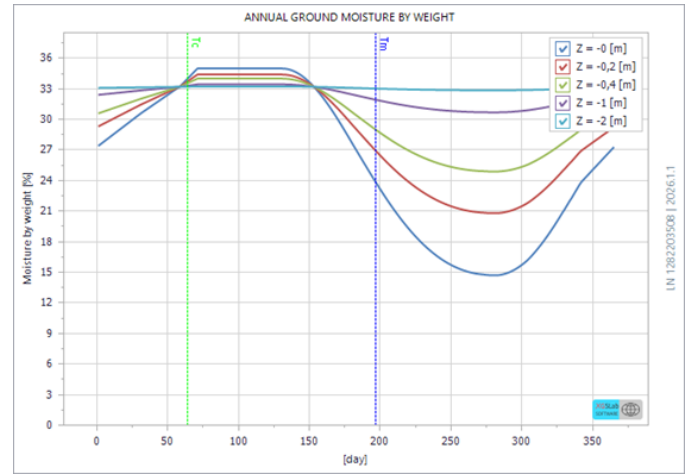

Annual ground moisture by weight

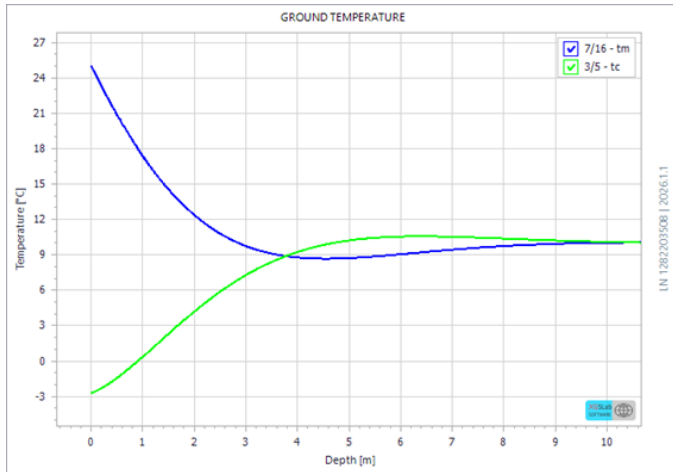

Ground temperature as a function of depth

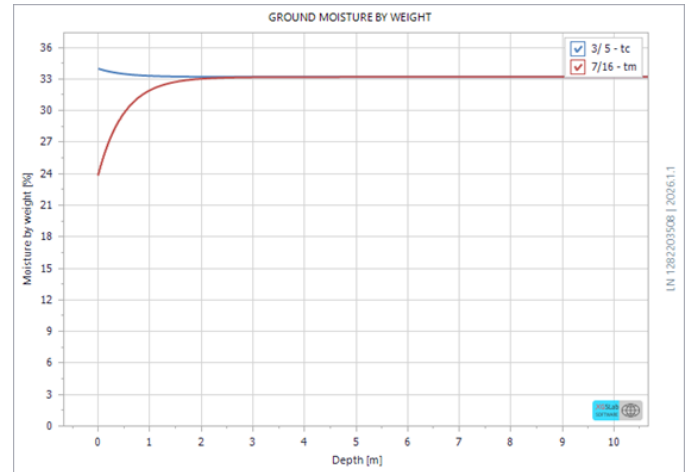

Ground moisture by weight as a function of depth

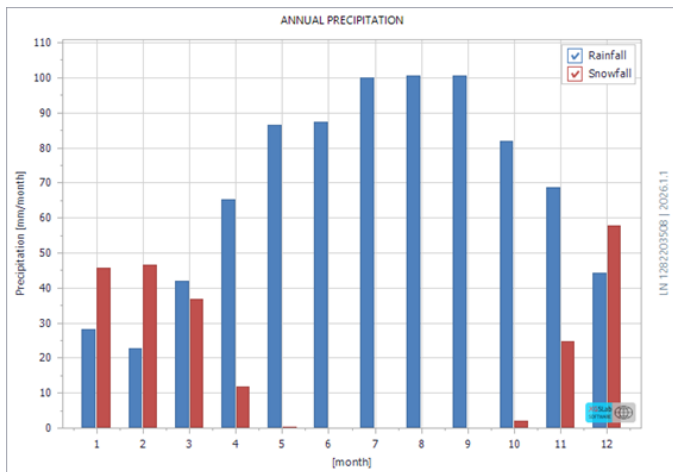

Annual precipitation

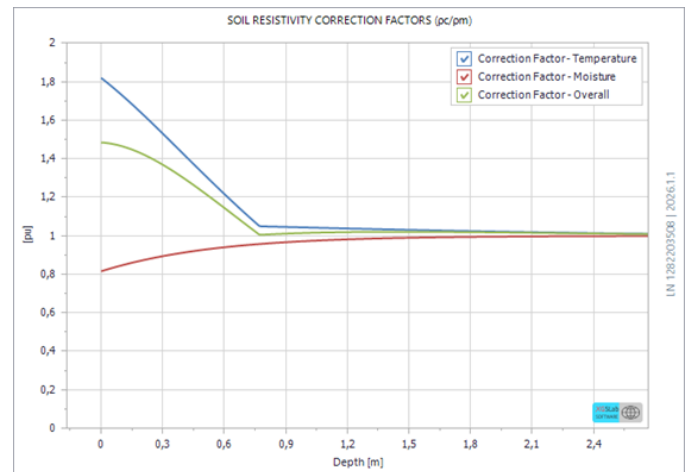

Soil resistivity correction factors as a function of depth

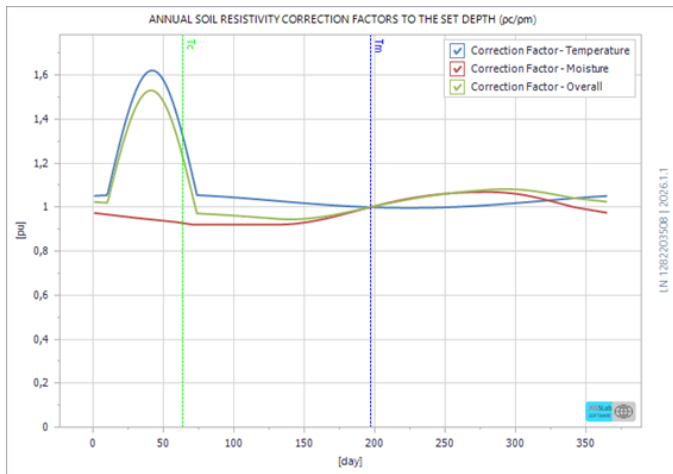

Annual soil resistivity correction factors to the set depth

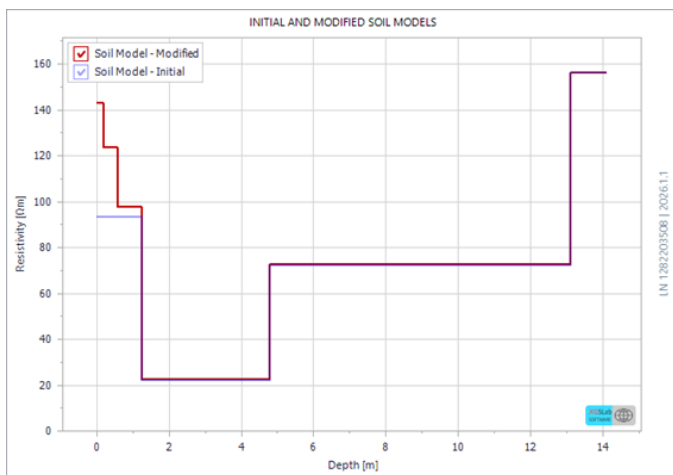

Initial and Modified Soil Models



SINT Srl

ENGINEERING CONSULTING AND SOFTWARE

THE EARTH REACTION

The earth reacts to the AC electromagnetic fields.

The exact solution of this problem was found by Sommerfeld and involves integrals (known as Sommerfeld integrals) that represent the solution of the Maxwell equations related to infinitesimal horizontal or vertical current elements radiating in the presence of a lossy half space. Sommerfeld integrals take into account the boundary conditions on the tangential components of the electromagnetic fields at the half space interface.

These integrals usually cannot be solved in closed form and in general are quite difficult to calculate also with a numerical approach because contain very oscillating Bessel functions.

The earth reaction to the AC electromagnetic fields grows with frequency and soil conductivity and is different for horizontal and vertical buried or aerial sources.

In order to display the earth reaction in an effective way, in the following, is represented the cross section of the magnetic field close an horizontal or vertical source on or above the soil surface.

In DC condition, there is no earth reaction.

At low frequency, the earth reaction is negligible for horizontal sources but significant for vertical sources.

At high frequency, the earth reaction becomes always relevant and the earth acts as a mirror for the magnetic field. With vertical sources this happen also at relatively low frequency.

Far from the source, the earth reaction is significant also at low frequency.

The following figures show the electric and magnetic fields distributions related to a single and long overhead line at different frequencies. The area calculation is vertical and across the soil surface.

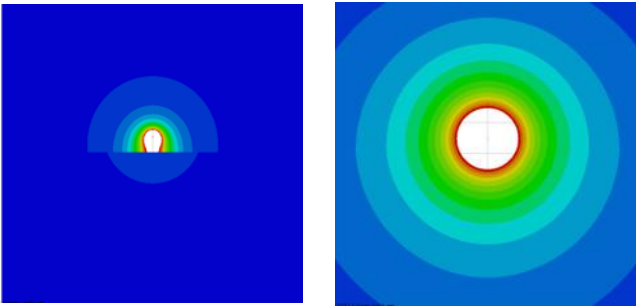

Electric Field (left) and Magnetic Field (right) at 10 kHz

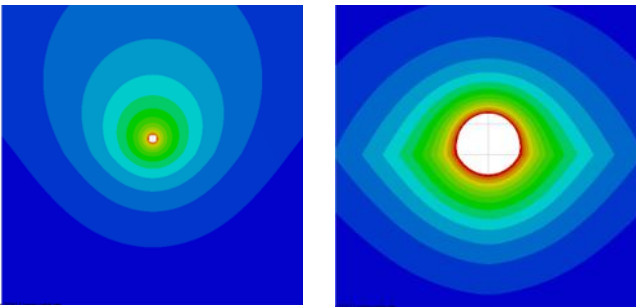

Electric Field (left) and Magnetic Field (right) at 1 MHz

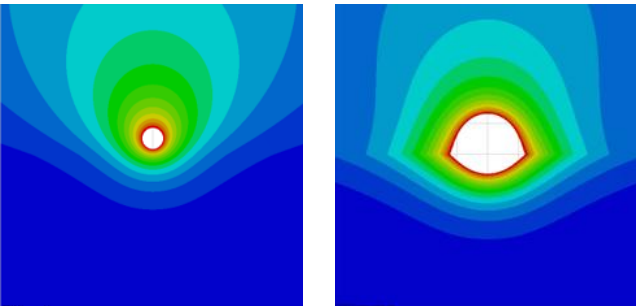

Electric Field (left) and Magnetic Field (right) at 10 MHz



SINT Srl

ENGINEERING CONSULTING AND SOFTWARE

THE GREAT THINKERS

The modules GSA, GSA_FD, XGSA_FD and XGSA_TD are based on Maxwell equations, Green functions and Sommerfeld integrals.

The module NETS is based on Kirchhoff laws.

The module SHIELD is based on Rolling Sphere and Eriksson methods and a numerical model.

The module SHIELD_A is based on Rolling Sphere method and an analytical model.

Most people know that the electromagnetic fields are governed by a set of experimental laws known as Maxwell equations and circuits are governed by Kirchhoff laws. On the other hand, not many people know about the fundamental studies carried out by Green, Lorentz and Sommerfeld, about the Fourier transforms, and on the discovery made by G. Ferraris.

G. Green studied the solution of inhomogeneous differential equations and the so called Green functions are fundamental solutions of these equations satisfying homogeneous boundary conditions. For instance, the Green functions can be used as solutions of the Laplace equation that governs the scalar potential in a uniform or stratified propagation medium in quasi-static conditions. XGS uses the Green functions for the calculation of the scalar potential in the multilayer soil model.

H.A. Lorentz has been one of the most important theoretical physicist in the World and is known also for the Lorentz force which describes the combined electric and magnetic forces acting on a charged particle in an electromagnetic field. XGS uses the Lorentz equation for the calculation of the electromagnetic forces.

A.J.W. Sommerfeld studied the earth reaction to the electromagnetic field and the rigorous solutions of the half space problem are known as Sommerfeld integrals. XGS implemented the Sommerfeld integrals for the calculation of the vector potential of horizontal or vertical electric dipoles.

Without these studies would not have been possible to develop XGS.

Furthermore, the calculation in the time domain were been possible by using the Fourier transforms. Fourier transforms allow moving from the time domain and vice versa.

G. Ferraris was one of the pioneers of AC power systems and an inventor of the polyphase power transmission systems, induction motor and alternator, some of the greatest inventions of all ages.

It is also important to be grateful to the scientists and engineers that have works in this field of research as for instance J.R. Carson (1886), S.A. Schelkunoff (1897), J.R. Wait (1924) and E.D. Sunde (1927).

Of course, XGS is based on the works of other scientists and mathematician as for instance I. Newton (1643), L. Euler (1707) and J.F.C. Gauss (1777) and many others that in more recent times contributed to improve the computing science.

In the future, it is easy to predict that software will make significant progress thanks to the Artificial Intelligence (AI), and XGS will have to take this into account. At the moment, XGS uses AI in writing code and customer support, but its use will gradually involve also the calculation routines. In short, progress does not stop.

For all this we like to say that XGSLab is "Science for Engineering".



Jean-Baptiste Joseph Fourier
(Auxerre 1768 – Paris 1830)



George Green
(Nottingham 1793 – Nottingham 1841)



Gustav Robert Kirchhoff
(Königsberg 1824 – Berlin 1887)



James Clerk Maxwell
(Edinburgh 1831 – Cambridge 1879)



Galileo Ferraris
(Livorno 1847 – Torino 1897)



Hendrik Antoon Lorentz
(Arnhem 1853 – Haarlem 1928)



Arnold Johannes Wilhelm Sommerfeld
(Königsberg 1868 – Munich 1951)



John Renshaw Carson
(Pittsburgh 1886 – New Hope 1940)



Sergei Alexander Schelkunoff
(Samara 1897 – Hightstown 1992)